

**FK50**

## Maintenance manual

Types:

FK50/460 K	FK50/555 K	FK50/660 K	FK50/775 K
FK50/460 N	FK50/555 N	FK50/660 N	FK50/775 N
FK50/460 TK	FK50/555 TK	FK50/660 TK	FK50/775 TK
FK50/830 K	FK50/980 K		
FK50/830 N	FK50/980 N		

# Foreword

Dear Customer,

Bock compressors are top-quality, reliable, service-friendly quality products. Please comply with the following operating and maintenance instructions so that you can benefit from all advantages to the full and use your refrigerating system throughout its entire service life. If you have any questions about installation, operation and accessories, please contact our technical service or your refrigerating system wholesale dealer or our representative. The Bock service team is available by phone under +49 7022 9454-0, by e-mail under [mail@bock.de](mailto:mail@bock.de) or on the internet under [www.bock.de](http://www.bock.de). In addition, for German speaking countries we have set up a toll-free hotline under 00 800 / 800 000 88 from Monday to Saturday between 8 a.m. and 9 p.m. Any suggestions you may have regarding the on-going development of our compressor, equipment and parts programme are welcome at any time.

**Please read the information summarised for you in this manual before starting work.**

**It contains important instructions for safety, installation, initial commissioning and handling. In addition you will find information on maintenance, spare parts and accessories.**

**Some instructions are identified by special symbols with the following meaning:**



**WARNING!** This symbol is used to indicate that inaccurate compliance or total failure to comply with the instructions could cause injury to persons or damage to the compressor or refrigerating machine.



**DANGER!** This symbol refers to instructions for avoiding direct severe dangers to persons.



**DANGER!** This symbol refers to instruction for avoiding direct severe dangers to persons or plant by electrical current.



**This symbol indicates important additional instructions which you should observe during your work.**

---

The high quality standard of Bock compressors is guaranteed also by on-going further development of machine, features and accessories. This could possibly result in non-conformities between this present manual and your compressor. Please understand that it is not possible for any claims to be derived from the details, illustrations and descriptions.

Your team at

Bock Kältemaschinen GmbH

**- Subject to modification -**

# Contents

Page

<b>Introduction</b>	<b>5</b>
<b>Safety instructions</b>	<b>5</b>
<b>Product description</b>	<b>6</b>
Short description, nameplate, type code	6
Main and functional parts	7
Dimension drawing, connections	8
Technical data	9
<b>Maintenance</b>	<b>10</b>
Function checks, oil level check, oil change	10
Operation of the shut-off valves	11
<b>Fault diagnosis / Remedying the malfunction</b>	<b>12</b>
General, function faults - symptoms	12
Compressor stand still	12
Compressor cutoff	13
Refrigerant performance too low	14
Compressor temperature too high	14
Oil problems	15
Abnormal running noise from compressor	15
Malfunction of the electromagnetic clutch	16
<b>Installation of service kits</b>	<b>17</b>
Safety	17
Leak oil collection ring, Part no. 80019	18
Shaft seal, Part no. 80023	19
Capacity regulating valve, Part no. 07541	20
Valve plate	21
<b>Electromagnetic clutch</b>	<b>23</b>
<b>Compressor defects</b>	<b>25</b>
<b>Disassembly of compressor</b>	<b>26</b>
Removal of the compressor from the refrigerant system	26
Disassembly of compressor	26
1 Removal of all shut-off valves and blind flanges	27
2 Removal of oil filter	28
3 Removal of the cylinder cover and of the valve plates	29
4 Removal of the shaft seal	30
5 Removal of the oil pump	31
6 Removal of the baseplate	32
7 Disassembly of the connecting rods from the crankshaft	33
8 Removal of the bearing flange	34
9 Removal of the crankshaft	35
10 Removal of the pistons and connecting rods	36
11 Removal of the remaining parts	37
12 Removal of the roller bearings	38

# Contents

	Page
<b>Checking the components of the compressor for damage / wear</b>	<b>39</b>
Limiting values for wear	39
Cylinder liners	39
Crankshaft	39
Pistons	40
Connecting rods	40
Valve plates	40
Oil pump	40
Oil filter / suction filter	41
Internal safety valve	41
<b>Assembly of the compressor</b>	<b>42</b>
1 Fitting the roller bearings	42
2 Fitting the sight glass, the plugs and the internal safety valve	43
3 Assembly of the pistons / connecting rods	44
4 Fitting the piston / connecting rod sets	45
5 Fitting the crankshaft	46
6 Installation of the front bearing flange	47
7 Assembly of the inserted connecting rods / pistons	48
8 Installation of the oil pump	49
9 Fitting the shaft seal	50
10 Installation of the baseplate	51
11 Installation of the oil filter	52
12 Installation of the cylinder cover and valve plates	53
13 Installation of the shut-off valves and blind flanges	54
Checking the compressor	55
<b>Tightening torques for screws</b>	<b>55</b>
<b>Spare parts list</b>	<b>56</b>
<b>Repair kits parts list</b>	<b>58</b>
<b>Parts list for optional accessories</b>	<b>59</b>
<b>Exploded drawing</b>	<b>60</b>

# Introduction

Vehicle compressors Series FK50 of Bock are among the most wide-spread machines used for bus A/C applications. The criteria that speak for choosing a FK50 compressor are its compact dimensions, its low weight, the wide capacity spectrum together with the high operating safety and service-friendliness.

This maintenance manual is intended to make the repair and maintenance of the FK50 easier for the servicing personnel. The maintenance manual contains a complete description of each work step for the disassembly and assembly of the compressor components. Each step must be carefully adhered to in order to ensure a reliable repair.

## Reminder:

- For replacing components Bock provides suitable spare part kits. Yet assembly jobs which go beyond the replacement of the shaft seal, the valve plates and - if there is one - the capacity regulator (accessory) should be checked carefully for their economic efficiency beforehand.
- The maintenance manual describes the standard type of the FK 40 compressor which we deliver. Because of different system conceptions, some passages in this service manual may differ from the unit which you have come across. In these cases the present manual should be used in analogous fashion.

# Safety



## Safety instructions

**Attention! Refrigeration compressors are machines under pressure and as such require special care in handling.**

- Only qualified personnel are allowed to perform any work on refrigeration compressors.
- The national safety regulations, accident prevention regulations, technical rules and specific regulations (EN 378 and others) must be taken into account absolutely.
- Do not exceed the maximum operating pressure - not even for purpose of checking!
- Never put the safety switch out of action!
- Prior to commissioning, check whether all the components installed by the user have been fastened expertly and connected pressure-tight with the compressor (e.g. piping, plugs, union nuts, replaced components etc.)
- Before commissioning, evacuate the refrigerant systems carefully including the compressor and afterwards charge refrigerant.
- Prior to starting the compressor open discharge shut-off valve and suction shut-off valve.
- Do not start the compressor in vacuum. Operate the compressor only when the system is charged.
- According to the conditions of use surface temperatures in excess of 100°C may occur on the discharge side and temperatures below 0°C on the suction side.
- Never grab rotating parts during operation! Danger of injury!

# Product description

## Product description

Series FK50 vehicle compressors are designed for mobile applications.

### Short description

Three design variations are available for different areas of application:

- > For air conditioning **the K Design**
- > For air conditioning or normal cooling **the N Design**
- > for deep freezing **the TK Design**

The differences are mostly associated with the valve plate version which is adapted to each application range where operational safety and efficiency are concerned.

### More features:

- Compact 6-cylinder compressor in W design.
- Wear resistant and long-lasting engine.
- Six sizes as regards capacity.
- Aluminium light-weight construction.
- Crankshaft supported in roller bearings on both sides.
- Bidirectional lubricating oil pump with relief valve.
- Variable arrangement shut-off valves.
- Ideally equipped with valve plates for each application.
- Integrated pulsation damper for especially quiet running.

### Nameplate (Example)

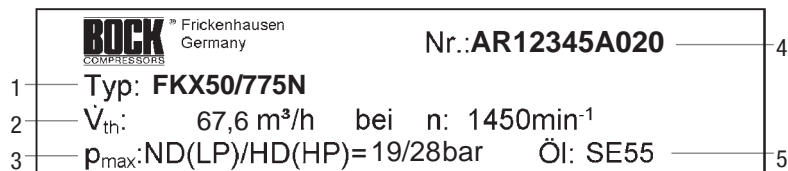

- 1. Type of compressor
  - 2. Volume baláye bei 1450 1/min
  - 3. LP: max. tol. stand still pressure intake side  
HP: max. tol. Derating pressure high pressure side
  - 4. Serial number
  - 5. Oil type filled in compressor by the manufacturer
- } **note limits of application diagrams!**

### Type code (Example)

Explanation of the type designation

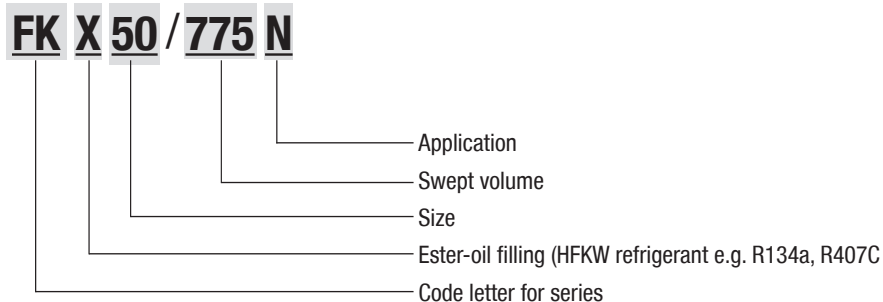

# Product description

## Main and functional parts

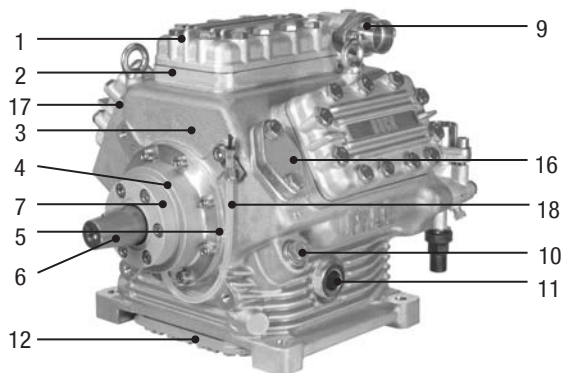

- |  |   |
|--|---|
| 1. Cylinder cover                            | 12. Baseplate   |
| 2. Valve plate                               | 13. Suction shut-off valve                                  |
| 3. Compressor casing                         | (FK50/660, 775, 830 and 980 with 2 suction shut-off valves) |
| 4. Integrated leak oil collector             | 14. Oil pump  |
| 5. Location hole for fitting magnetic clutch | 15. Oil drain shut-off valve / oil filter                   |
| 6. Shaft end                                 | 16. Optional connection type for suction shut-off valve     |
| 7. Shaft seal                                | 17. Nameplate   |
| 8. Connection thermal protection thermostat  | 18. Leak oil drain hose                                     |
| 9. Discharge shut-off valve                  |   |
| 10. Oil filling plug                         |   |
| 11. Sight glasses for oil (2x)               |   |

# Product description

## Dimension drawing

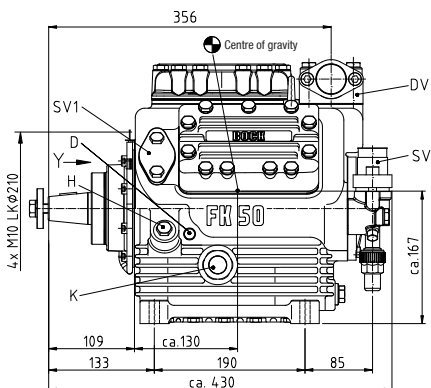
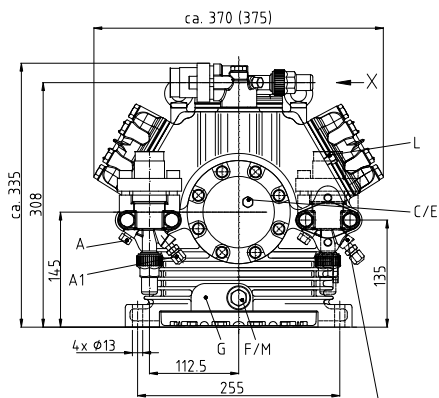

- additional SV at FK50/660, 775, 830 and 980 standart  
 - () = K-Design

Dimensions in mm

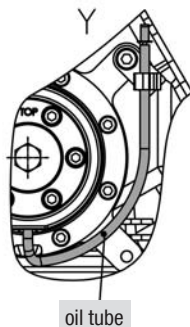
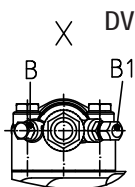
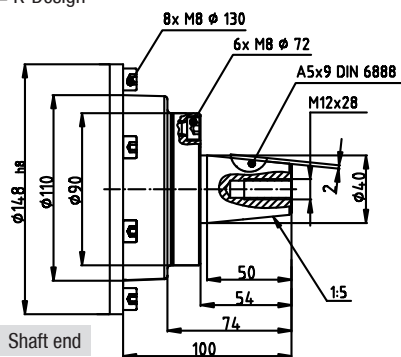

## Connections

<b>A</b>	Suction side connection, not lockable	1/8" NPTF
<b>A1</b>	Suction side connection, lockable	7/16" UNF
<b>B</b>	Discharge side connection, not lockable	1/8" NPTF
<b>B1</b>	Discharge side connection, lockable	7/16" UNF
<b>C</b>	Oil pressure safety switch connection OIL	1/8" NPTF
<b>D</b>	Oil pressure safety switch connection LP	1/8" NPTF
<b>E</b>	Oil pressure gauge connection	1/8" NPTF
<b>F</b>	Oil drain	M22 x 1.5
<b>G</b>	Optional connection oil sump heater <sup>1)</sup>	--
<b>H</b>	Oil charge plug	M22 x 1.5
<b>K</b>	Sight glass	2 x 1 1/8" -18 UNEF
<b>L</b>	Connection thermal protection thermostat	1/8" NPTF
<b>M</b>	Oil filter	M22 x 1.5
<b>SV1</b>	Optional connection suction valve	--

<sup>1)</sup> = Only possible from factory



# Product description

Type	Number of cyl.	Swept volume cm <sup>3</sup>	Displ. volume (1450 <sup>1</sup> /min) m <sup>3</sup> /h	Weight kg	Connections		Oil filling Ltr.	Inertia moment [kgm <sup>2</sup> ]	Lubrica- tion	Oil pump
					Discharge line DV mm / inch	Suction line SV mm/inch				
FK50/460	6	459	40,1	44	28 / 1 1/8	35 / 1 3/8	2,6	0,0047	Forced feed lubrication	Independent of direction of rotation
FK50/555		556	48,3	43	28 / 1 1/8	35 / 1 3/8				
FK50/660		662	57,6	42	35 / 1 3/8	2 x 35 / 1 3/8				
FK50/775		776	67,6	41	35 / 1 3/8	2 x 35 / 1 3/8				
FK50/830		831	72,3	43	35 / 1 3/8	2 x 35 / 1 3/8				
FK50/980		976	84,9	42	35 / 1 3/8	2 x 35 / 1 3/8				

The technical data are the same for the various design variants K, N and TK.  
In the data concerning the type of compressor, these additions are not taken into account.

# Maintenance

## Maintenance

### Service intervals

Practically no maintenance is required. However, for an optimal operating safety and service life of the compressor **we recommend** to carry out the necessary maintenance work regularly according to the specifications of the manufacturer of the refrigerating plant.

### Function checks to be carried out once a year:

- Leak test of the plant
- Checking the running noise of compressor
- Checking pressures and temperatures of the plant
- Checking the tensioner for orderly seating
- Checking the V belts for tension and condition
- Checking the oil level in the crankcase
- Checking the fixing screws for tightening
- Checking the function of the ancillary units
- Checking the electrical connections for clean, firmly fixed contacts and the leads for chafing points

### Oil level check

After starting the compressor, the oil level has to be checked. For this:

- The driving engine should be in the „High idle“ operating condition (elevated idling speed).
- Compressor running time at least 10 min.
- The plant should have reached the operating point.
- The oil level must be visible in the sight glass.

### Changing oil:

In case of orderly manufactured and operated plants an oil change is in principle not absolutely necessary.

Yet, based on decades-long experience we recommend to carry out the following oil change and servicing.

- First oil change at the first maintenance of the vehicle.
- After that, changing the oil every 5000 operating hours, but at the latest after 3 years. At the same time the oil filter and the suction filter should be cleaned and the oil connecting ring from the shaft seal replaced.

### Lubricants

Standard oil type used by Bock	Recommended alternatives	
For H-FCKWs (e.g. R22)		
<b>FUCHS Reniso SP 46</b>	MOBIL SHC 425 SHELL Clavus SD 22-12	SUNOIL Suniso 4GS TEXAKO Capella WF 46
For FKWs (e.g. R 134a, R404A, R407C)		
<b>FUCHS Reniso Triton SE 55</b>	FUCHS SEZ 32 / 68 / 80 ICI Emkarate RL 46 S	MOBIL Arctic EAL 46 SHELL Clavus R 46

Information about other suitable oils should be taken from Bock lubricant tables. Information may also be retrieved from [www.bock.de](http://www.bock.de).

# Maintenance

## Operating of the shut-off valves

### Opening the shut-off valve

- a) Spindle 1: Turn to the left (ccw) until the end stop.
- Shut-off valve fully open / Service port 2 closed (Position A), Fig.

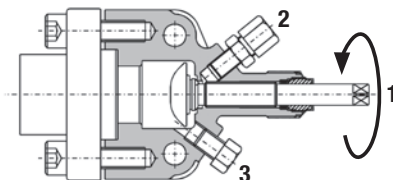

### Opening the service port (2)

- b) Spindle 1: Turn 1/2 - 1 turn to the right
- Service port 2 open / Shut-off valve open (Position B), Fig.
- Port 3 is intended for safety devices and cannot be shut-off.

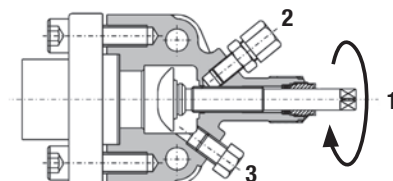

**Note:** Before opening or closing the shut-off valve, loosen the valve spindle seal (Fig. left) by 1/4 turn. After operating the shut-off valve, tighten the valve spindle seal carefully again (Fig. right).



# Fault diagnosis

## Fault diagnosis

In case of malfunctions during compressor operation we recommend to prepare a measurement record for aiding the fault search:

- Pressure measurement: Discharge side, suction side, oil pressure
- Temperature measurement: Compressor casing, discharge end temperature, suction gas overheating.

According to the expected cause of the fault it may be necessary to check the electrical systems for faults in the control.

In order to localize the causes of operating malfunctions as easy as possible we have compiled the following table with suggestion for remedying compressor malfunctions.

## Function faults-Symptoms

Function faults arising most frequently and their symptoms are:

- Compressor stoppage, compressor cutoff
  - Compressor does not start
  - Compressor starts and then stops again
- Refrigerant performance too low
- Too high compressor temperature
- Oil problems
- Abnormal compressor running noise
- Malfunction of the electromagnetic clutch

## Compressor stand still

### ● Compressor does not start

Symptom	Possible cause	Remedy
Open circuit	- Fuse blown  Cutoff through: <ul style="list-style-type: none"><li>- Low pressure switch</li><li>- High pressure switch</li><li>- Heat protection thermostat</li><li>- Control thermostat</li><li>- Other safety elements</li></ul>	- Replace fuse Determine and remove the cause - Localize the interruption in the circuit and remove the cause of the interruption
Malfunction of electromagnetic clutch	- see also p. 16 „Malfunction of electromagnetic clutch“	- Checking

# Fault diagnosis

## Compressor cutoff

### • Compressor starts and stops again

Symptom	Possible cause	Remedy
Cutoff through low-pressure switch	<p>Suction pressure too low:</p> <ul style="list-style-type: none"> <li>- Check the setting of the low pressure switch</li> <li>- Suction valve of the compressor closed</li> <li>- Capacity of compressor too large</li> <li>- Refrigerant deficiency</li> <li>- Filter / dryer in the liquid line blocked</li> <li>- Expansion valve not functioning properly</li> <li>- Solenoid valve on the liquid line not opening</li> </ul>	<ul style="list-style-type: none"> <li>- Adjust the switching points or replace switch</li> <li>- Open shut-off valve</li> <li>- Check operating conditions</li> <li>- Leak test / Add refrigerant</li> <li>- Replace filter / dryer</li> <li>- Check the setting of the valve</li> <li>- Check the control / function</li> </ul>
Cutoff through high-pressure switch	<p>Condensing pressure too high:</p> <ul style="list-style-type: none"> <li>- Check the setting of the high-pressure switch</li> <li>- Pressure valve of the compressor closed</li> <li>- Condenser fan not functioning</li> <li>- Condenser dirty</li> <li>- Excessive refrigerant filling</li> <li>- Non-condensable gases in refrigerant</li> </ul>	<ul style="list-style-type: none"> <li>- Adjust the switching points or replace switch</li> <li>- Open shut-off valve</li> <li>- Check the control / replace motor</li> <li>- Cleaning of condenser</li> <li>- Extract refrigerant to normal filling</li> <li>- Extract refrigerant and evacuate the refrigeration plant / refill refrigerant</li> </ul>
Cutoff through heat-protection thermostat (accessory)	<p>Discharge end temperatures is too high</p> <ul style="list-style-type: none"> <li>- Operating limits of compressor exceeded</li> <li>- Suction gas overheating</li> <li>- Refrigerant of the condenser insufficient</li> <li>- Valve plate damage</li> <li>- Internal safety valve has opened</li> </ul>	<ul style="list-style-type: none"> <li>- Adapt the operating conditions to the operating range.</li> <li>- Check expansion valve / Check insulation on the suction side</li> <li>- Check fan motors / Clean the condenser</li> <li>- Replace valve plate</li> <li>- Replace safety valve</li> <li>• Check compressor and refrigeration plant Determine and remove the cause for the inadmissible high pressure in the high-pressure side</li> </ul>
Cutoff through control thermostat	<ul style="list-style-type: none"> <li>- Temperature over / below the desired range</li> </ul>	<ul style="list-style-type: none"> <li>- Check operating points</li> </ul>

# Fault diagnosis

## Refrigerant performance too low

Symptom	Possible cause	Remedy
Suction pressure too high	<ul style="list-style-type: none"> <li>- Expansion valve not functioning properly</li> <li>- Lack of compressor capacity</li> </ul>	<ul style="list-style-type: none"> <li>- Check valve setting; replace valve, if necessary</li> <li>- Check the function of the compressor by evacuating to vacuum.</li> <li>Check function of capacity regulator (accessory)</li> </ul>
Suction pressure too low	- See „Cutoff through low-pressure switch“	- Checking
High-pressure too high	- See „Cutoff through high-pressure switch“	- Checking
High-pressure too low	<ul style="list-style-type: none"> <li>- Condenser being cooled to much</li> <li>- Lack of compressor capacity</li> <li>- Pressure laminations of valve plate leaking</li> <li>By-pass between suction and discharge side</li> </ul>	<ul style="list-style-type: none"> <li>- Adjust the control of condenser cooling</li> <li>- Check compressor / Check the functioning of capacity regulator</li> <li>- Replace valve plate</li> <li>Localize leak between the discharge and suction side and repair it</li> </ul>

## Refrigerant temperature too high

Symptom	Possible cause	Remedy
Suction gas temperature too high	<ul style="list-style-type: none"> <li>- Suction gas overheating</li> <li>- Too little refrigerant filling</li> <li>- Liquid filter blocked</li> </ul>	<ul style="list-style-type: none"> <li>- Adjust expansion valve</li> <li>Insulate the gas suction line</li> <li>- Establish the operating filling (see Operating Instruction for the refrigeration plant)</li> <li>Localize leak</li> <li>- Clean / replace filter / dryer</li> </ul>
Discharge pipe temperature too high	<ul style="list-style-type: none"> <li>- Suction gas temperature too high</li> <li>Condensing pressure too high</li> <li>- Operating limits of compressor exceeded</li> <li>- Cooling insufficient</li> <li>- Short circuit between the discharge and the suction side of the compressor</li> <li>- Valve plate damage</li> <li>- Internal safety valve has opened</li> </ul>	<ul style="list-style-type: none"> <li>• see point above</li> <li>• see „Cutoff through high-pressure switch“</li> <li>• see „Cutoff through heat-protection thermostat“</li> <li>- Replace defective valve plate</li> <li>- Replace safety valve (see the section on Dismantling / Assembly of Compressor)</li> </ul>

# Fault diagnosis

## Oil problems

Symptom	Possible cause	Remedy
Oil pressure too low	<ul style="list-style-type: none"> <li>- Refrigerant in oil</li> <li>- Too little oil in compressor</li>   <li>- Oil filter dirty / blocked</li> </ul>	<ul style="list-style-type: none"> <li>- see „Oil foams“</li> <li>- Add oil and search for the cause of oil loss</li> <li>- Clean / replace oil filter</li> <li>Change oil</li> </ul>
Oil foams during start-up phase	<ul style="list-style-type: none"> <li>- Liquid refrigerant has moved into the oil sump</li> </ul>	<ul style="list-style-type: none"> <li>- Check the laying of pipes</li> <li>- Installation of the check valve in the discharge line</li> <li>- Installation of the solenoid valve in the liquid line</li> <li>- Check the control</li> </ul>
Oil foams during operating	<ul style="list-style-type: none"> <li>- Expansion valve not functioning</li> </ul>	<ul style="list-style-type: none"> <li>- Adjust / replace expansion valve</li> </ul>
Oil level decreases	<ul style="list-style-type: none"> <li>- During start-up, a portion of the oil is carried to the refrigeration plant with the refrigerant</li>   <li>- Refrigerant in oil</li>   <li>- Piston rings worn</li> <li>- Suction / discharge laminations of the valve plate leaking</li> </ul>	<ul style="list-style-type: none"> <li>- Refrigerant and oil get mixed. After some time the oil level should stabilize.</li> <li>Add oil, if necessary.</li> <li>- see „Oil foams during operation“</li> <li>- Replace piston rings</li> <li>- Replace valve plate</li> </ul>

## Abnormal running noise from compressor

Symptom	Possible cause	Remedy
Fixation of compressor is loose	<ul style="list-style-type: none"> <li>- Screwed connections have become loose</li> <li>- Securing elements for screwed connections missing</li> <li>- Vibration metals defective</li> </ul>	<ul style="list-style-type: none"> <li>- Tighten the screwed connections and secure them anew</li>   <li>- Replace vibrations metals</li> </ul>
Liquid shock	<ul style="list-style-type: none"> <li>- Liquid refrigerant reaching the compressor</li>   <li>- Oil shocks because of too much oil</li> </ul>	<ul style="list-style-type: none"> <li>- Adjust / check expansion valve</li> <li>Check refrigerant filling</li> <li>Check evaporator fan</li> <li>Icing-up of the evaporator</li> <li>- Check oil level</li> <li>Check the dimensioning of pipes (gas velocity)</li> <li>Replace worn piston rings</li> </ul>
Capacity regulator (accessory)	<ul style="list-style-type: none"> <li>- switching on and off constantly / oscillating</li> <li>- defective</li> </ul>	<ul style="list-style-type: none"> <li>- Check the control</li> <li>- Replace capacity regulator valve</li> </ul>
Electromagnetic clutch slipping	<ul style="list-style-type: none"> <li>- see also p. 16 „Malfunction of electromagnetic clutch“</li> </ul>	<ul style="list-style-type: none"> <li>- Checking</li> </ul>
V belt drive, increased noise generation	<ul style="list-style-type: none"> <li>- Belts vibrating excessively</li>   <li>- Incorrect alignment of compressor and motor</li> </ul>	<ul style="list-style-type: none"> <li>- Check belt tension</li> <li>Use tensioning roller / guidance roller</li> <li>- Check alignment and adjust anew</li> </ul>

# Fault diagnosis

## Malfunction of the electromagnetic clutch

Symptom	Possible cause	Remedy
Clutch not switching	<ul style="list-style-type: none"><li>- No voltage applied</li></ul>	<ul style="list-style-type: none"><li>- Apply voltage and check</li></ul>
Clutch slipping too long, getting hot, smoking and squeaking	<ul style="list-style-type: none"><li>- Voltage too low</li><li>- Driving power too high</li><li>- Rotor rubbing at the magnetic field</li></ul>	<ul style="list-style-type: none"><li>- Keep the voltage at 12 or 24 Volts (check vehicle network)</li><li>- Check operating conditions</li><li>- Check the seating of the magnet possibly to high belt tension</li></ul>
Clutch not separating	<ul style="list-style-type: none"><li>- Voltage still being applied to the magnet</li><li>- Clutch is stuck</li> <li>- Clutch overloaded, Armature disc is deformed</li></ul>	<ul style="list-style-type: none"><li>- Check switch / relay</li><li>- Disconnect the armature disc from the rotor mechanically</li><li>- Install new rotor and armature disc</li></ul>



# Installing of service kits

## Disassembly-Assembly of service kits



In principle, the same safety remarks described on page 5 of this Service Manual are valid.

Furthermore the following should be taken into account:

**Before starting any work on the compressor:**

- Switch of the machine and guard it against switching on.
- Close the discharge and suction shut-off valves.
- Relieve the compressor from system pressure.
- Use only genuine Bock spare parts.

**After the work is finished:**

- Connect the safety switch and check its function.
- Evacuate the compressor.
- Before commissioning, check whether all the components installed by the user have been mounted expertly and connected pressure-tight to the compressor (e.g. piping, plugs, union nuts, replaced components etc.
- Open the pressure and suction shut-off valves (see page 11).
- Set off the switching-on lock.

For changing components in the framework of customary service works we recommend the kits described on the following pages.

# Installing of service kits

## Leak oil collection ring (Part No. 80129)

### Procedure:

- Remove the leak oil collection ring (see Fig. 1)
- The repair kit contains two felt inlays (Pos. 2 and Pos.3, see Fig. 2).
- If the bearing flange with one oil pocket is installed Pos. 2 must be inserted (see Fig. 4).
- If the bearing flange with six oil pocket is installed Pos. 2 must be inserted (see Fig. 4).
- If the wrong felt inlay, or both felt inlays, is inserted the functioning of the oil collection system cannot be ensured.

Leak oil collection ring



Fig. 1

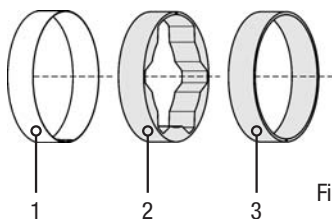

Fig. 2

### Type code 001

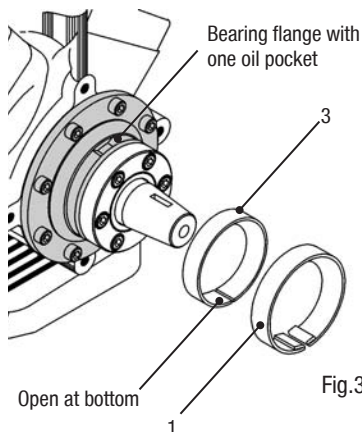

Fig.3

### Type code 007 - 013

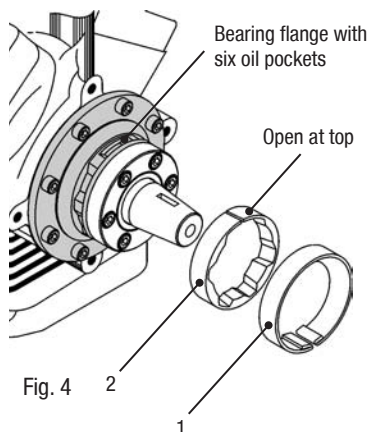

Fig. 4

### Starting from type code 015- (starting from 4th quarter 2005)

**Emptying the oil reservoir:** The oil reservoir can be emptied very simply without having to dismantle the coupling and/or belt drive. It is recommended that this is done at the same time as the air-conditioning maintenance and motor service. Proceed by removing the oil hose from the bracket, remove the sealing plug and drain the oil into a collecting vessel. After emptying, the bracket. Dispose of used oil in accordance with the regulations applicable in the country of use.



# Installing of service kits

## Shaft seal (Part No. 80023)

### Removal:

- Dismount the drive/magnetic clutch from the compressor.
- Remove the Woodruff key from seat at the shaft end.
- Remove the leak oil collection ring (9) and the felt inlay (8a or 8b, according to the type) (for this, see Fig. 1 on page 18).
- Unscrew the screws (7) from the shaft seal cover (6).
- Remove the gasket residues and the shaft seal cover gasket (5) from the bearing flange.



**Attention: The shaft seal cover (6) is under spring tension. The remaining oil may run out of the shaft seal chamber. Keep a suitable collection container ready!**

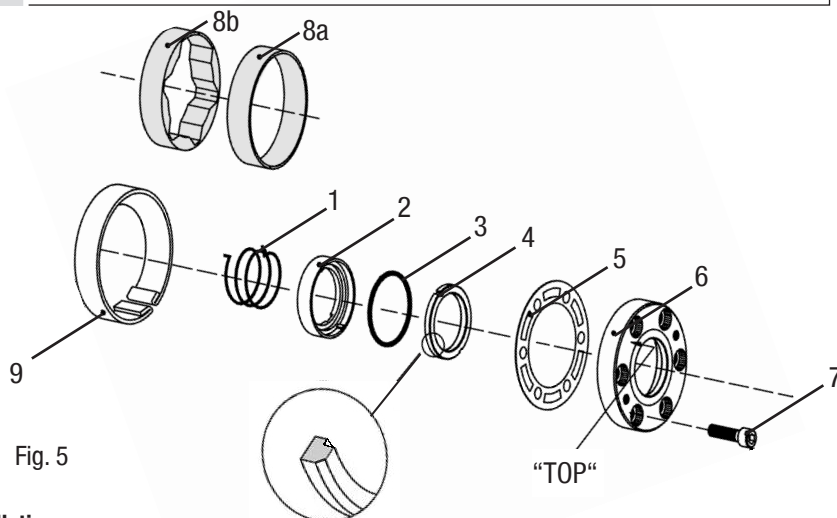

Fig. 5

### Installation:

- Work with utmost cleanliness.
- Always replace the shaft seals complete, never individual parts thereof.
- Do not use used parts.
- Prior to installation, check the sliding and sealing surfaces for cleanliness and damages.
- Apply a **thin film of oil** on the sealing surfaces of the sliding ring (4), shaft seal cover (6), O-ring (3) and the compressor shaft (use compressor oil).
- Assemble the sliding ring (4), O-ring (3) and the guide ring (2) together as a unit. The large chamfer on the sliding ring (4) should show in the direction of the shaft seal cover (6).
- During the assembly the compression spring (1) must engage audibly in the drive slot of the crankshaft and of the guide ring (2).
- Install the shaft seal cover gasket (5) dry, don't impregnate it with oil.
- Install the shaft seal cover (6) with the inscription „TOP“ upwards. Tighten the fixing screws (7) evenly, crosswise tightening torque = 37 Nm.
- After installing the shaft seal, turn the compressor shaft a few turns by hand and then carry out the leak test.
- Install the leak oil collection ring (see section on leak oil collection ring, page 18).
- Insert the Woodruff key into the seat at the compressor shaft end.
- Mount the drive/clutch.

# Installing of service kits

## Capacity regulation

The capacity regulation takes place through the turning off of the suction gas flows by means of a solenoid valve on the cylinder cover. For this, the valve is activated electrically by a thermostat or pressostat.

- During normal operation the solenoid is de-energized and the suction gas channel in the valve plate and in the cylinder cover is open.
- During regulated operation the solenoid is energized and the suction gas flow is closed through the shut-off piston of the solenoid valve. The compressor pistons of the cylinder bank which is regulated down run idle. The capacity of the compressor is still approx. 50%.

Further information together the description of the working principle of the solenoid valve is contained in the publication „Capacity regulation“ (Part no. 09900).

## Capacity regulation valve (Part No. 07541)

(Only for the capacity regulation which is an accessory)

### Removal:

- De-energize the solenoid (4).
- Screw on the fixing nut (3), pull out the solenoid (4) with the washer (5).
- Unscrew the valve body (2).
- Check the valve body (2) for damages and whether the piston moves freely. If necessary, replace the complete valve body (2).

### Installation:

- Screw on the valve body (2) with the enclosed new O-ring (1) and tighten it.
- Push on the washer (5) and the solenoid (4) and fasten them with the fixing nut (3).
- Put the compressor into operation and check the functioning if the capacity regulation.

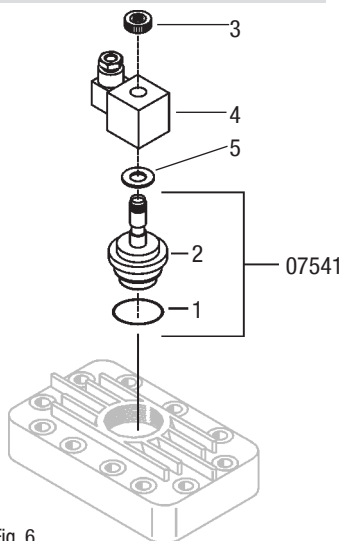

Fig. 6

# Installing of service kits

## Valve plate

Compressor type	Parts kit (Part No.)	Compressor type	Parts kit (Part No.)
FK50/480 N	80243	FK50/460 TK	80243
FK50/555 N	80243	FK50/555 TK	80243
FK50/660 N to FK500/980 N	80244	FK50/660 TK	80244
FK50/460 N to FK50/980 K	08926	FK50/775 TK	80244

K type Valve plate

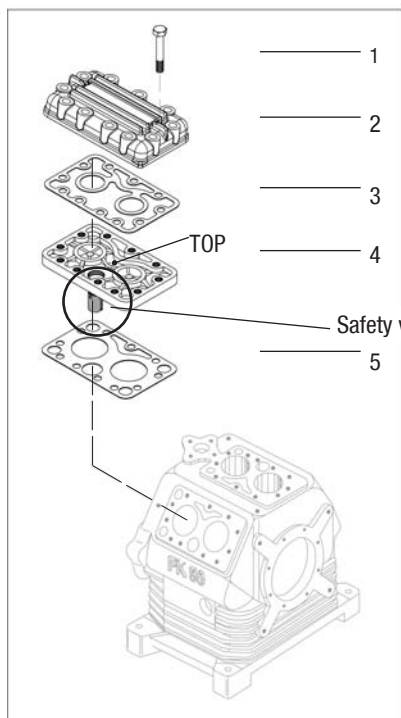

N type and TK type Valve plate

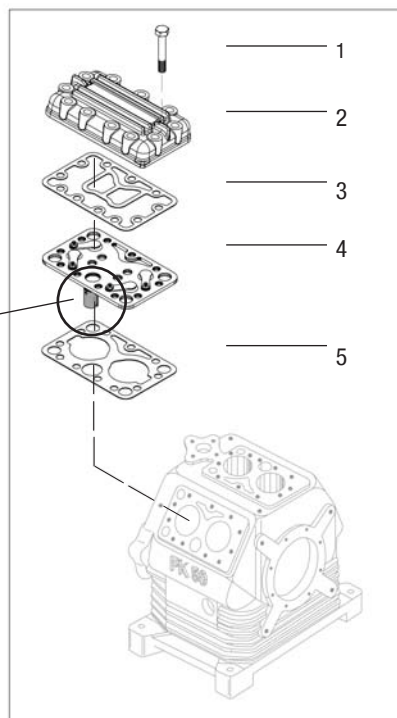

Fig. 7

# Installing of service kits

**Removal** (see Fig. 7):

- Unscrew the screws (1) from the cylinder cover (2) and dismount cylinder cover.
- Remove the gasket residues from the body of the compressor.



**Reminder: Don't let any gasket residues fall into the compressor.**

**Installation** (see Fig. 7):



**Attention: The conversion of the compressor from one type of valve plate to another is not possible!**

- Apply a little oil to the lower valve plate gasket (5) install the upper valve plate gasket (3) (metallic gasket) dry.
- Pay attention to the correct installation position of the gaskets (3, 5) of the valve plate (4) and of the cylinder cover (2).



**Attention: Install the K type valve plate (Part no. 80010) only with the inscription „TOP“ facing upwards (see Fig. 7).**

- Tighten the cylinder cover screws (Pos. 1 in Fig. 7) according to the sequence shown in Fig. 8 observe the screw tightening torque (see Table on Page 55)!.

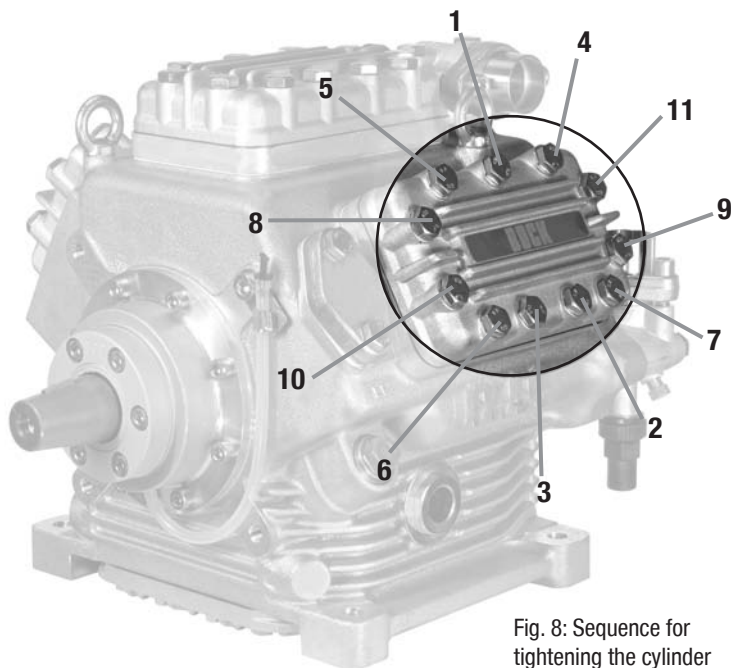

Fig. 8: Sequence for tightening the cylinder cover screws

# Electromagnetic clutch

## Assembly instruction for electromagnetic clutch

For the drive of A/C compressors in buses, mainly electromagnetic clutches are used. The followings assembly instructions for clutch type LA 16 is representative for clutches which are mounted onto the front bearing flange of the compressor.

### Assembly instruction for electromagnetic clutch Type LA 16 (Type LA 26 at FK50/830 and FK50/980)

- The front bearing flange has a location face  $\varnothing 148$  h8 for fitting the solenoid of the electromagnetic clutch (see Fig. 9).

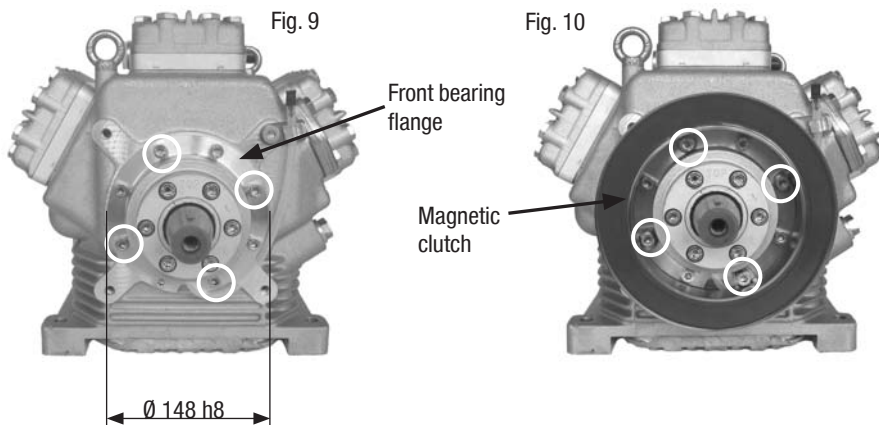

- For fitting the solenoid (1) remove the four M8x25 cylinder screws (2) on the bearing flange (indicated with circles and arrows in Fig. 9 on page 23 and Fig. 11 on page 24).
- Fit the solenoid onto the location seat and fasten it again with the four M8x25 cylinder screws (Fig. 10). Observe the screw tightening torque (see Table on page 55)!



**Attention! Use only M8x25 screws! Otherwise, serious damages may occur on the electromagnetic clutch and the compressor.**

# Electromagnetic clutch



**Reminder: Arrange the cable (8) so that it doesn't touch hot parts (e.g. protection pipe).  $t_{\max} = 105^{\circ}\text{C}$ !**

- Remove the K-circlip (5) and the clamping screw (4) from the rotor assembly (3). Looking through the rotor hole, pay attention to the correct seating of the Woodruff key in the rotor slot. It should be possible to turn the rotor by hand without the rotor touching the solenoid. Pay attention to the checking projection! Screw on the clamping screw (4) and tighten it. Screw tightening torque: 85 Nm. Install the K-circlip (5).
- Push the sheave (6) over the studs (9) and fasten it with zinc-coated M8 DIN 934-8 nuts (7).
- Connect the cable (8). The connection is polarity-independent. Voltage  $\pm 10\%$  of nominal voltage.



**Reminder for dismounting: For dismounting the clutch apply grease to the K-circlip and turn the clamping screw (4) to the left for unscrewing.**



**Attention! With all other methods of removal (pressing, hammering) there is risk of damage to the clutch.**

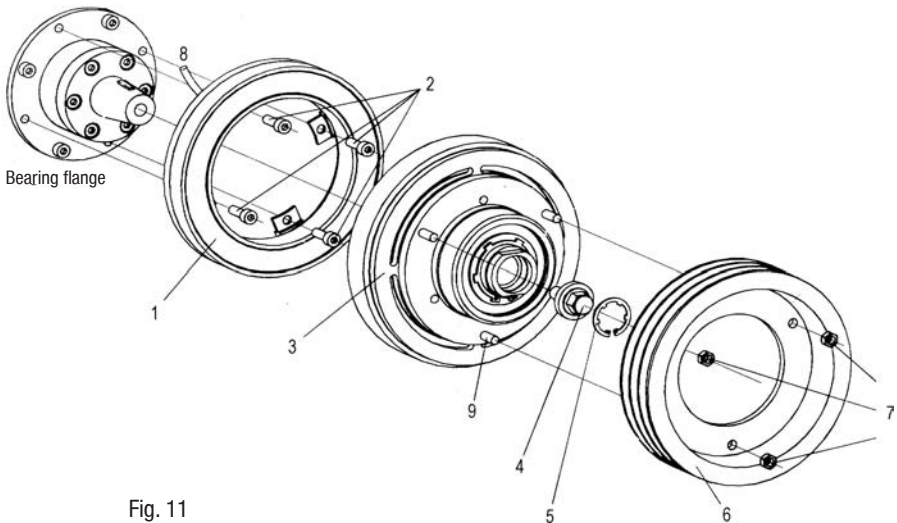



# Compressor defects

## Compressor defects

Compressor defects may have various causes. The table below is meant to aid you while analysing the cause of the breakdown by means of the defective compressor parts found. Thus, the specific remedying of the cause of the breakdown is facilitated.

Compressor part	Possible causes Symptom	Remedy
Valve plate	<ul style="list-style-type: none"> <li>- Liquid shocks because of liquid refrigerant or oil</li> <li>- Overheating of compressor</li> </ul>	<p><u>Liquid shocks:</u></p> <ul style="list-style-type: none"> <li>- Check, adjust expansion valve, replace it, if necessary; check refrigerant charge</li> <li>- Check evaporator fan</li> <li>- In case the evaporator is iced-up: Check the dimensioning of piping (gas velocity).</li> </ul>
Shaft seal leaking	<ul style="list-style-type: none"> <li>- Lack of oil</li> <li>- Standstill time too long</li> <li>- Dirt in the system</li> <li>- Moisture in the system</li> <li>- Too frequent starting of the compressor</li> <li>- Overheating of compressor</li> <li>- Belt vibrating excessively</li> <li>- Alignment of compressor and motor incorrect</li> </ul>	<p><u>Overheating of compressor</u> (Heat protection thermostat switches off):</p> <ul style="list-style-type: none"> <li>- Check the operating conditions</li> </ul> <p><u>Lack of oil:</u></p>
Oil pump	<ul style="list-style-type: none"> <li>- Lack of oil</li> <li>- Dirt in the system</li> <li>- Moisture in the system</li> <li>- Overheating of compressor</li> </ul>	<ul style="list-style-type: none"> <li>- Dirt in the system: Change oil, clean the system; install a suction line filter, if necessary.</li> </ul>
Bearings	<ul style="list-style-type: none"> <li>- Lack of oil</li> <li>- Dirt in the system</li> <li>- Moisture in the system</li> <li>- Overheating of compressor</li> <li>- Overloading of compressor</li> </ul>	<p><u>Moisture in the system /</u> <u>Acid formation in the system:</u></p> <ul style="list-style-type: none"> <li>- Dry the system trough changing refrigerant and oil, replace the drier; install a suction line filter, if necessary.</li> </ul>
Pistons / Connecting rods	<ul style="list-style-type: none"> <li>- Lack of oil</li> <li>- Dirt in the system</li> <li>- Moisture in the system</li> <li>- Overloading of compressor</li> </ul>	<p><u>Frequent starting and stopping of compressor:</u></p> <ul style="list-style-type: none"> <li>- Overloading of compressor</li> <li>- Compare the operating conditions with the application limits</li> </ul>
Copper plating	<ul style="list-style-type: none"> <li>- Moisture in the system</li> <li>- Acid formation in the system</li> </ul>	<ul style="list-style-type: none"> <li>- Remove defects in belting</li> </ul>
Formation of oil-carbon	<ul style="list-style-type: none"> <li>- Overloading of compressor</li> </ul>	

# Disassembly of the compressor

## Removal of the compressor from the refrigerant system

### a) Removal of the compressor from the system; shut-off valves remaining on the compressor

- Extract the refrigerant from the system into a container which may be used for this refrigerant.
- Evacuate the systems including the compressor.
- Cut off the vacuum, humid air should not get into the system.
- Close the shut-off valves on the suction and discharge side; remove the compressor.
- Close the suction and discharge line connection points on the system with stoppers.
- Relieve the pressure before dismantling the compressor.

### b) Removal of the compressor from the system; shut-off valves for compressor remaining at the system

- Close shut-off valves on the suction and discharge side.
- Extract the refrigerant from the compressor into a container which may be used for this refrigerant.
- Evacuate the compressor.
- Cut off the vacuum.
- Remove the compressor from the system.
- Close the suction and discharge shut-off ports on the compressor with stoppers.

## Disassembly of compressor

The disassembly of the compressor is explained in separate steps on the following pages. The indicated parts list positions refer to the spare parts lists, repair set lists, special accessories part lists and the exploded drawing at the end of the maintenance manual.



### Preparation: Necessary tools

**Reminder! For the removal and installation of the internal safety valve the BOCK special tool Part No. 09524 is necessary (only up to design key 015)!**

Pos.	Tool	Size
1	Oil collection container	> 2,6 ltr.
2	Spanner	SW 10, 13, 14, 17, 19, 30, 36
3	Allen key	6 mm, 10 mm
4	Seeger circlip plier, Form C	8 - 13 mm
5	Pulling apparatus	
6	Pressing apparatus	
7	Piston ring plier	
8	Dial gage	
9	Bock special tool, Part No. 09524	



**Reminder: With compressors starting from year of construction 2008/09 the oil pump, the shut-off valves, the valve plate and the cylinder covers are bolted with washers. In the individual work sections separately with these washers does not deal.**

**When assembling the washers must be used again on the installation!**

Step

1

## Removal of all shut-off valves and blind flanges

Parts list position: **2060, 2070, 232**

Tools: **Spanner SW 17, allen key 6 mm**

Pos. in  
parts list

Working course

- |          |  |
|----------|--|
| 220      | • Unscrew the fixing screws of shut-off valves |
| 330, 210 | • Remove the shut-off valves and the gaskets   |
| 230 ,210 | • Remove the suction filter and the gasket     |
| 233, 333 | • Remove the screws from the blind flange      |
| 232, 231 | • Remove the blind flange and the seal         |
| 232, 331 |  |

Fig. 12



Step

**2**

## Removal of the oil filter

Parts list position: **2130**

Tools: **Oil collection container, spanner SW 19, Allen key. 10 mm**

Pos. in  
parts list

Working course

- Drain the oil from the compressor into a suitable container
- 510 • Unscrew the plug
- 500 • Remove the gasket
- 490 • Unscrew the oil filter

Fig. 13a

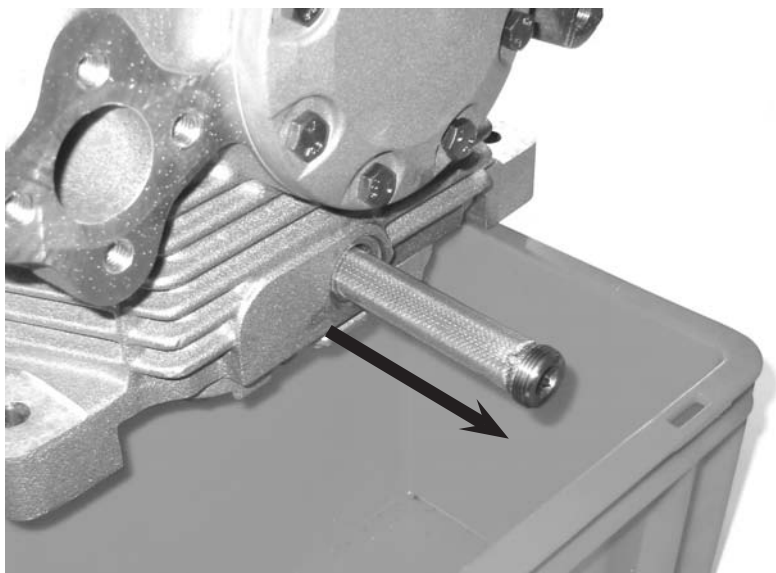

Fig. 13b



Step

3

**Removal of the cylinder cover and valve plates**

Parts list position: 170, 2000 (N / TK-versions), 1940, 2900 (K-version)

Tool: **Spanner SW 17****In order to prevent any mix-up during reassembly, mark the cylinder cover and the valve plates belonging together clearly and in a wipe-resistant fashion!**

Pos. in N / TK	parts list K	Working course
180	1950	<ul style="list-style-type: none"> <li>• Unscrew the cylinder cover screw</li> </ul>
170, 70	1940, 1930	<ul style="list-style-type: none"> <li>• Remove the cylinder cover and the upper gasket of the valve plate</li> </ul>
60, 50	1920, 1910	<ul style="list-style-type: none"> <li>• Remove the valve plate and the lower gasket of the valve plate</li> </ul>

Fig. 14a

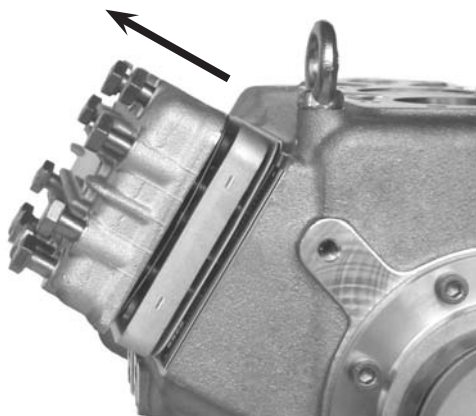

Fig. 14b



Step

4

## Removal of the shaft seal

Parts list position: 2010

Tools: Oil collection container, Allen key 6 mm



**For a detailed description see also the section on the removal of the shaft seal on page 19!**

Pos. in parts list	Working course
2110	<ul style="list-style-type: none"><li>• Place the oil collection container under the shaft seal area</li><li>• Remove the leak oil collection device from the bearing flange</li></ul>
750	<ul style="list-style-type: none"><li>• Unscrew the cylinder screws</li><li>• <b>(i) Watch out! The shaft seal cover is under spring tension! It may jump out by itself.</b></li></ul>
2010	<ul style="list-style-type: none"><li>• Remove the shaft seal cover, the guide ring, the O-ring and the spring.</li></ul>

Fig. 15a

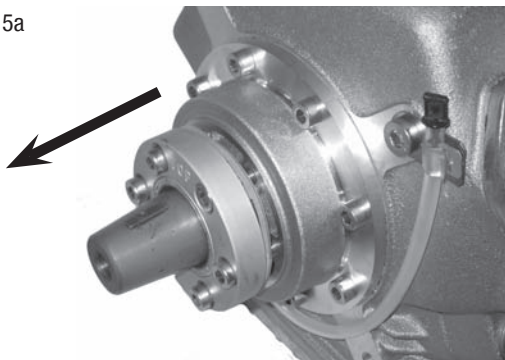
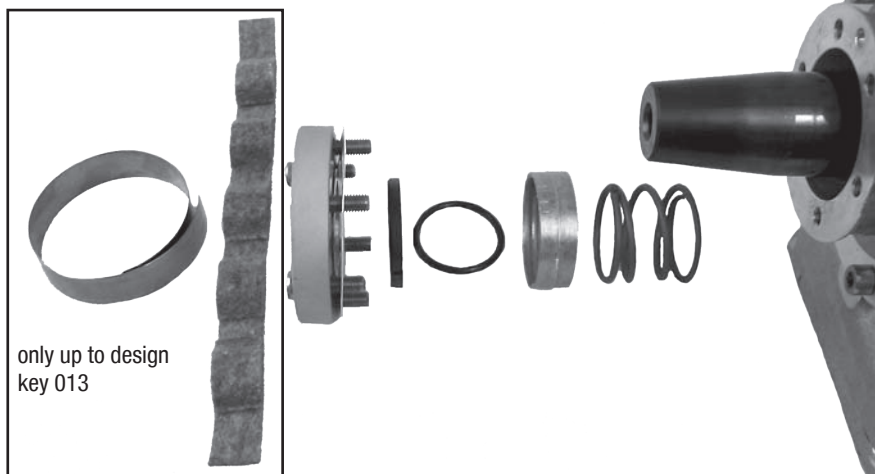

Fig. 15b



Step

**5**

## Removal of the oil pump

Parts list position: **2020**

Tools: **Spanner SW 13**

Pos. in  
parts list

Working course

40

- Unscrew the screws

460, 470

- Remove the oil pump and gasket

Fig. 16a

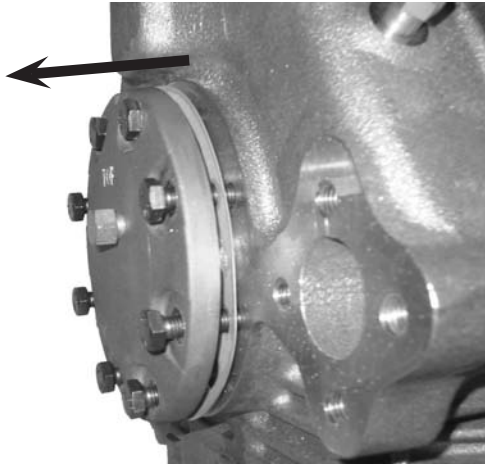
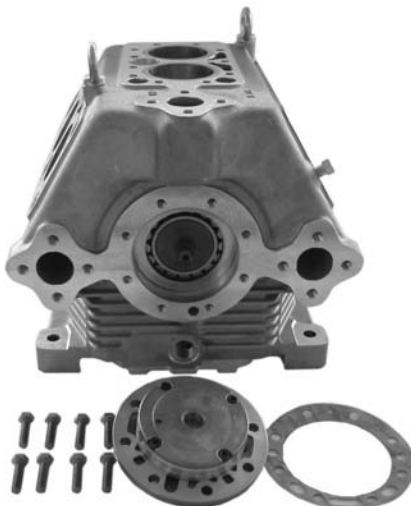

Fig. 16b



Step

6

## Removal of the baseplate

Parts list position: 20

Tools: Oil collection pan, spanner SW 13

Pos. in  
parts list

Working course

40  
20,30

- Place the compressor into the oil collection pan and turn it sideways
- Unscrew the screws from the baseplate
- Remove the baseplate and the gasket

Fig. 17a

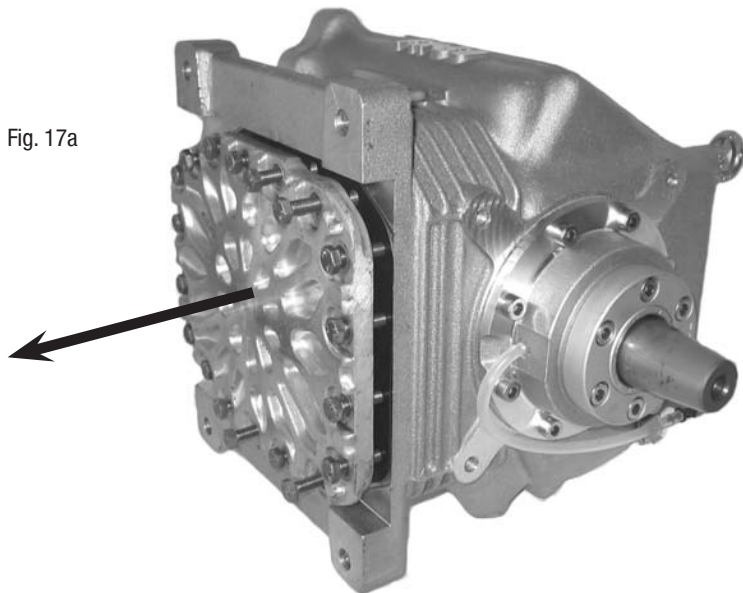

Fig. 17b





Step  
**7**

## Disassembly of the compressor rods from the crankshaft

Parts list position: **2100**

Tools: **Spanner SW 10**



**In order to prevent any mix-up during reassembly, mark the connecting rods and caps belonging together clearly and in a wipe-resistant fashion.**

Pos. in parts list	Working course
	<ul style="list-style-type: none"><li>● Unscrew the hexagon head screws from the connecting rod cap</li><li>● Mark the connecting rod cap and remove it.</li><li>● Push the piston and connecting rod upwards until the shop.</li><li>● Remove the piston rings.</li><li>● The same procedure should be applied for the remaining connecting rods</li></ul>

Fig. 18a

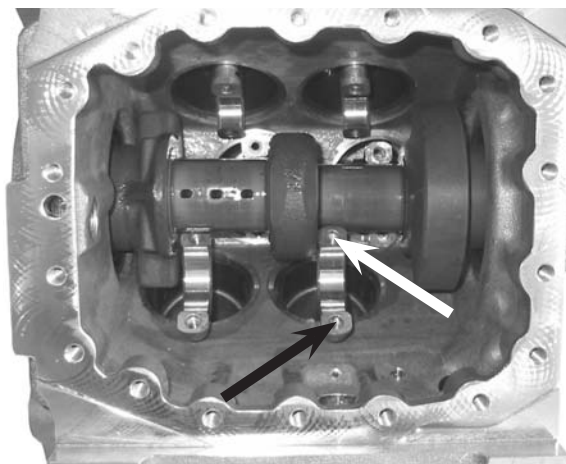
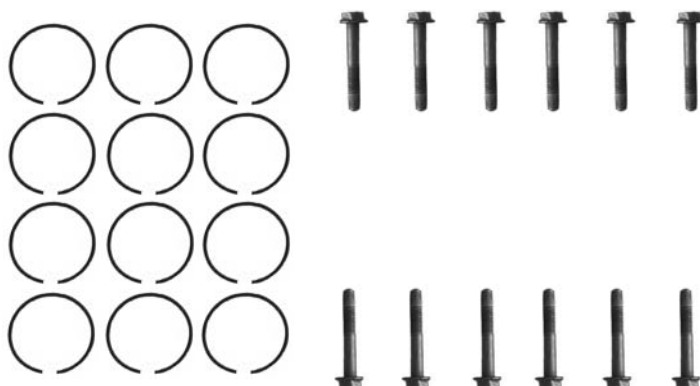

Fig. 18b



Step

8

## Removal of the front bearing

Parts list position: 2140

Tools: Allen key 6 mm

Pos. in parts list	Working course
750	<ul style="list-style-type: none"><li>• Unscrew the screws</li></ul>
730, 740, 745	<ul style="list-style-type: none"><li>• Remove the front bearing flange, gasket, and O-ring</li></ul>

Fig. 19a

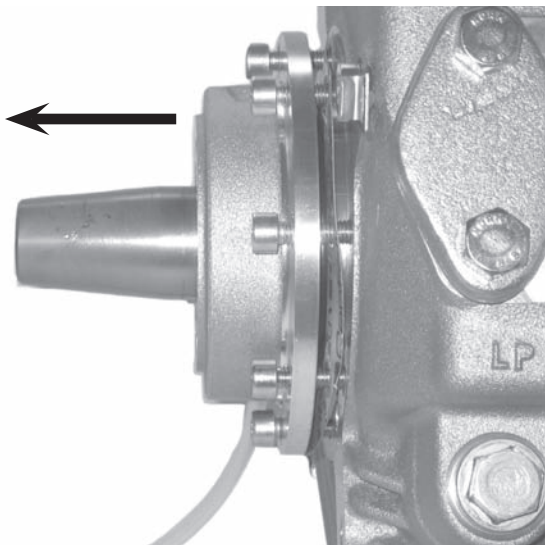
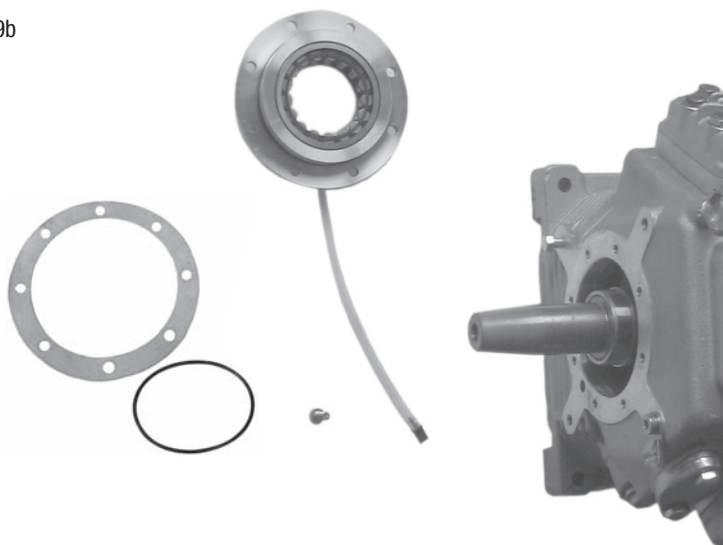

Fig. 19b



Step

9

## Removal of the crankshaft

Parts list position: **2050**

Tools: —

Pos. in  
parts list

Working course

- Pull out the crankshaft carefully in direction of the front bearing flange.

Fig. 20

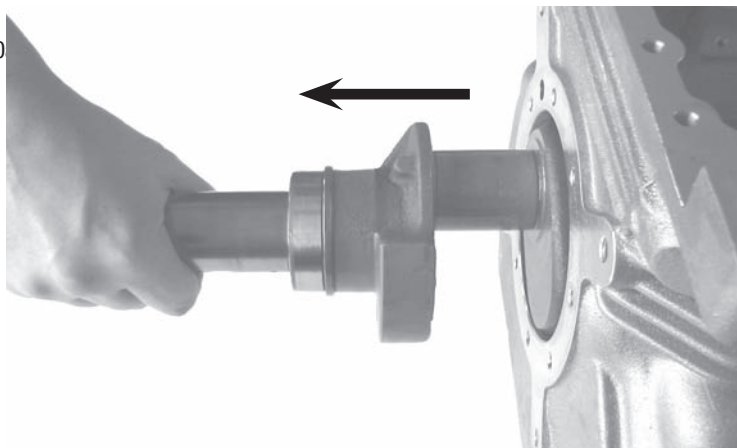
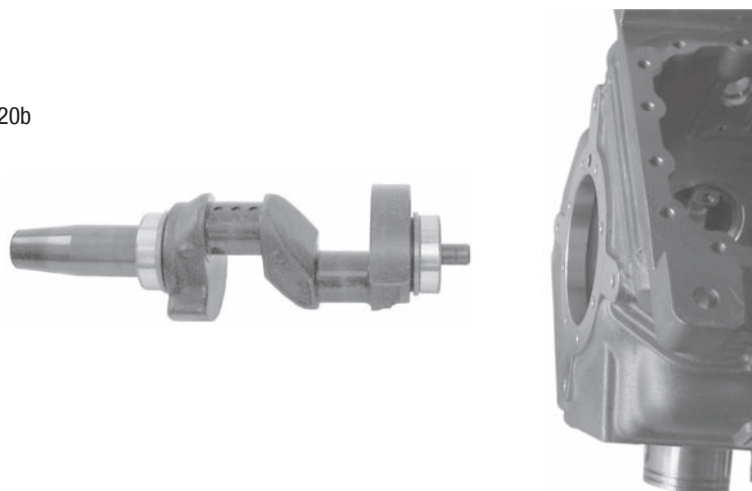

Fig. 20b



Step

## Removal of the pistons and connecting rods

# 10

Parts list position: 2040

Tools: **Seeger circlip plier from C 8-13 mm**

Pos. in parts list

Working course

280

270

- Mark the piston and the cylinder bore belonging together.
- Remove the piston / connecting rod in direction of baseplate.
- Remove the seeger circlip of the piston pins.
- Push the piston pins out of the pistons and remove pistons.
- In order to prevent mix-ups, fasten the connecting rod caps to the connecting rods again.

Fig. 21a

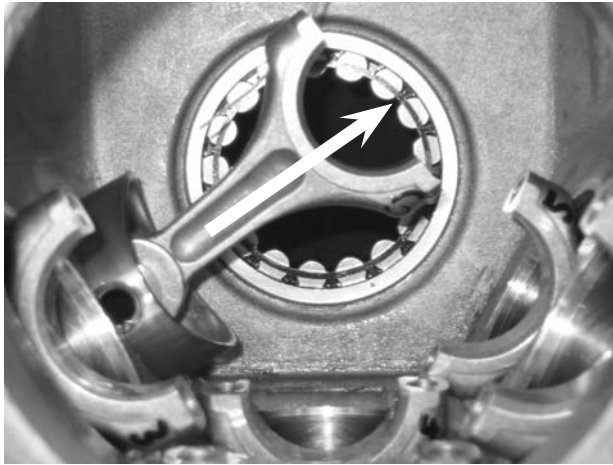
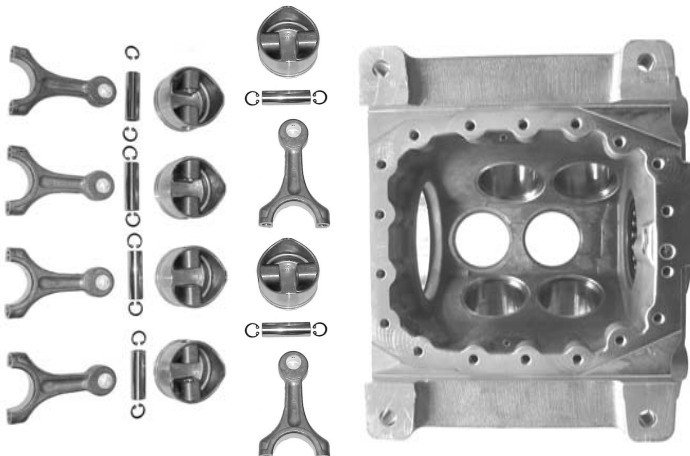

Fig. 21b



Step

11

## Removal of the remaining parts

Parts list position: -

Tools: **Spanner SW 13, 14, 30 o. 36**

Pos. in  
parts list

Working course

- |          |   |
|----------|---|
| 570      | ● Dismount the sight glass (use 30 mm or 36 mm spanner according to the type) |
| 590      | ● Remove O-ring   |
| 520      | ● Remove the 1/8" NPTF plugs  |
| 510, 500 | ● Remove the plug M22 x 1,5 with the seal                                     |

Fig. 22

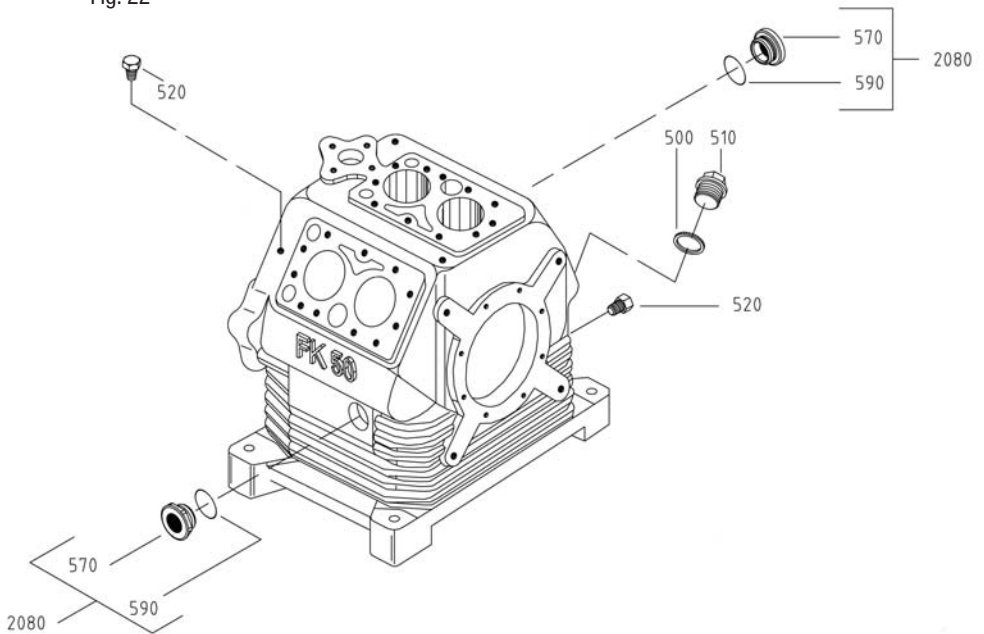

Step

**12****Removal of the roller bearings**Parts list position: **2150**Tools: **Pulling apparatus**Pos. in  
parts list

Working course

2150, 730

- With the pulling apparatus pull out the roller bearing from the front bearing flange.

**i Use oil, if necessary!**

If a pulling apparatus is not available, the front bearing flange may be heated for approx. 15 minutes in a pre-heated (220°C) baking oven. Afterwards the roller bearing can be pressed out by hand.

**⚠ WATCH OUT! Parts are hot! Use protective gloves!**

2150

- Press out the roller bearing from the compressor body.

312

- Take out the tolerance ring, if there is any.

**i Use oil, if necessary!**

Fig. 23a

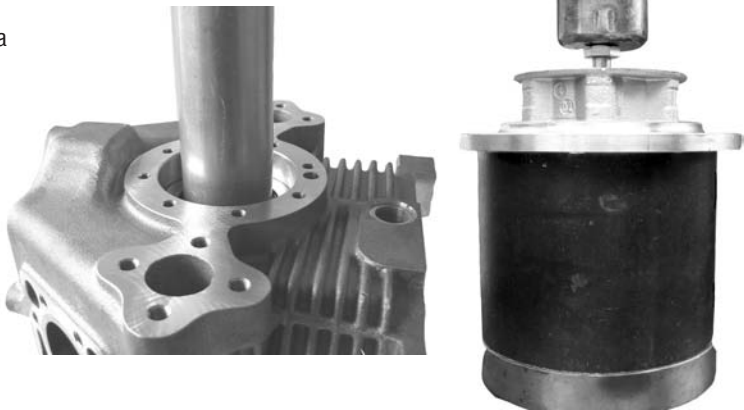

Fig. 23b



# Checking the compressor parts

## Checking compressor parts for damages / wear

- Before re-using removed compressor parts we recommend that they be checked for usability.
- The wear limits listed below should be taken into consideration

### Maximum allowable bearing play

① Piston-cylindre bore	0,13 mm
② Connecting rod-piston pin	0,03 mm
③ Crankshaft-connection rod bearing	0,08 mm

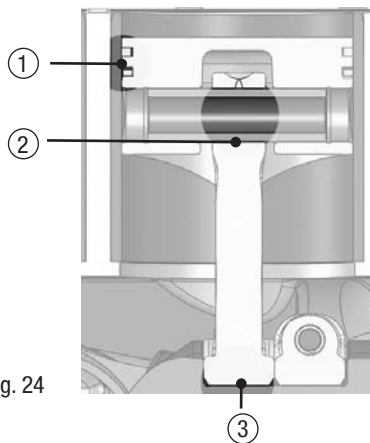

Fig. 24

Other components have to be examined according to the following criteria:

### • Cylinder liners

The cylinder liners should not have any visible damages in the piston movement area. If there is fluting, the casing should be replaced.

### • Crankshaft

The bearing surfaces should not have any damages. The oil channels should be clean so that an unhindered oil flow is ensured.

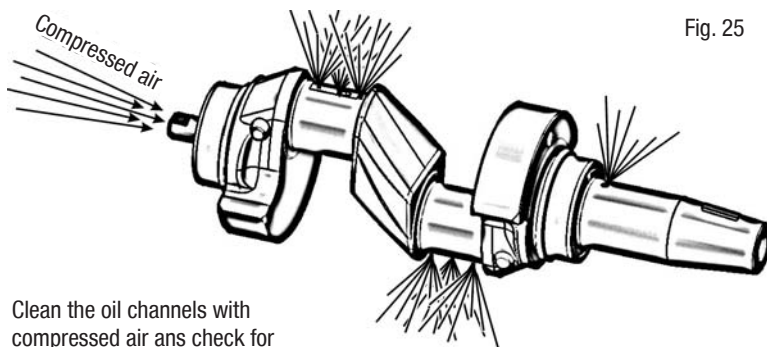

Fig. 25

Clean the oil channels with compressed air and check for passage

# Check the compressor parts

- **Pistons**

There should be no visible damages on the piston crown and the piston walls. The grooves for the piston rings must be clean and undamaged. Check the condition of the piston rings for wear, fractures and other irregularities.

- **Connecting rods**

There should be no damages on bearing surfaces.  
The connecting rod shank must be straight.

Fig. 26

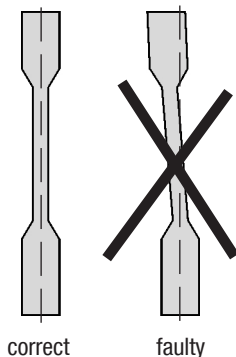

- **Valve plates**

Suction and pressure lamella must be undamaged and un-deformed. The sealing surfaces must be clean and undamaged. In case of a damage the valve plate must be replaced completely. Single lamella are not available.

- **Oil pump**

It must be possible to turn the oil pump by hand (turning to the left and to the right).  
In the removed conditioning the reversing device of the oil pump must switch over audibly.

Fig. 27

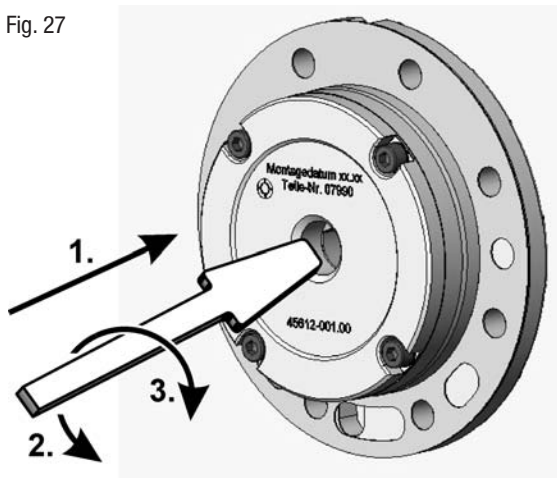



# Check the compressor parts

- **Oil filter / suction filter**

The filter screen must be in an undamaged condition. Dirt and residues have to be removed. If necessary, the filter have to be cleaned with compressed air or replaced with new ones.

- **Internal safety valve (use Bock special tool, Part No. 09524 up to A015\*, socket wrench SW 22 from A 017\*)**

The internal safety valve must be replaced after it has operated.

\*) see on the last four pages of the machine number

Fig. 28

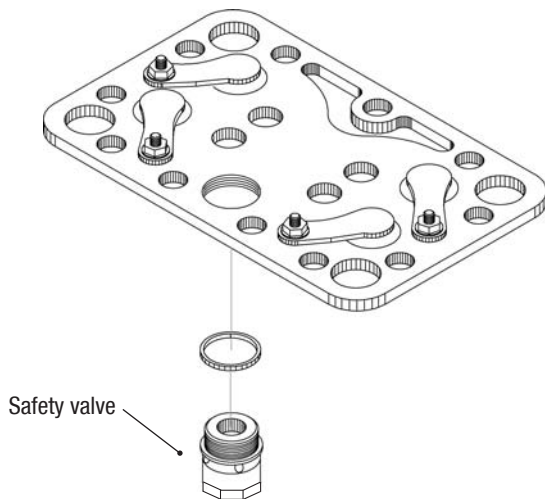

**In case of larger compressor damages which necessitate a complete disassembly of the compressor, we recommend in principle the replacement of the following assemblies:**

- Valve plates
- Piston rings
- Shaft seals
- Roller bearings

Thus, concealed defects of parts which have been in operation may be prevented.

# Assembly of compressor

Step

1

## Fitting the roller bearings

Parts list position: 310

Tools: Pressing apparatus

Pos. in  
parts list

Working course

- Heat the bearing flange / compressor casing for approx. 20 minutes in a pre-heated (120°C) baking oven.
- Press the roller bearings onto the compressor casing and the front bearing flange.

**⚠ WATCH OUT! Parts are hot! Use protective gloves!**

**ⓘ Use tolerance ring if the bearing seat has a groove!**



Fig. 29a

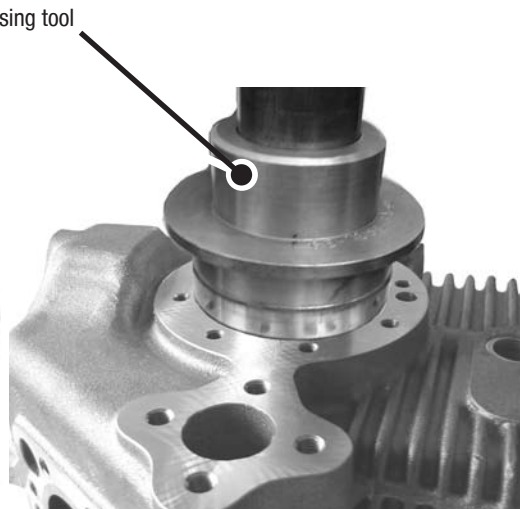

Fig. 29b

Step

2

## Fitting the sight glass, plugs

Parts list position: -

Tools: **Spanner SW 13, 14, 30 o. 36**



**Observe the screw tightening torques (see table on page 55)!**

Pos. in parts list	Working course
570, 590	● Screw on the sight glass with oiled O-ring to the compressor body.
520	● Screw on the 1/8" NPTF plugs.
500, 510	● Remove the plug M22 x 1,5 with the seal

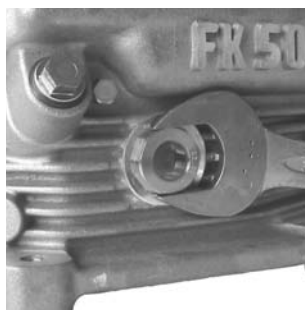
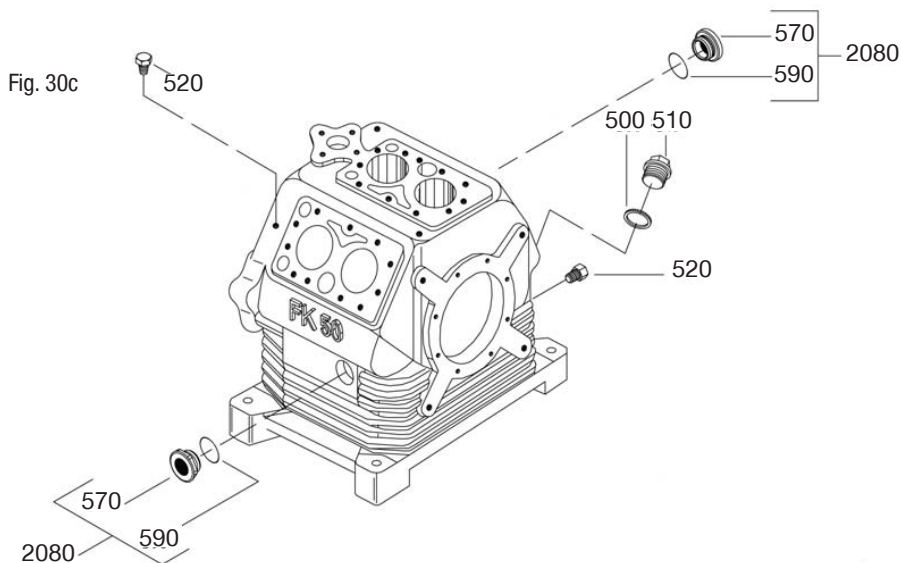

Fig. 30a



Fig. 30b



Step

3

### Assembly of the pistons / connection

Parts list position: 2040

Tools: **Seeger circlip plier Form C 8-13 mm**

Pos. in  
parts list

Work course

270  
280

- Assembly the pistons with the connecting rods (in the reverse sequence of the disassembly of compressor, step 7)
- Insert the piston pins; use oil, if necessary. (see. Fig. 31a).
- Install seeger circlips on both sides of the piston pins (see. Fig. 31b).

Fig. 31a



Fig. 31b

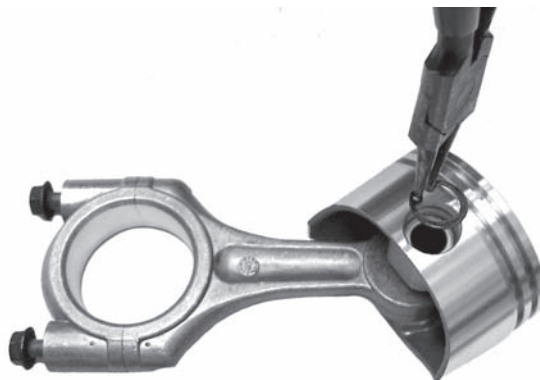

Step

4

## Fitting the piston / connecting rod set

Parts list position: 2040

Tools: Spanner SW 10



Take the markings of each part into account (see disassembly, step 7 on page 33)

Pos. in parts list	Working course
2100	<ul style="list-style-type: none"><li>Remove the connecting rod cap from the preassembled connecting rod assembly and mark it.</li></ul>
2040	<ul style="list-style-type: none"><li>Apply a little oil to the cylinder bore.</li><li>Insert the piston / connecting rod assemblies from the opening in the baseplate into the cylinder liners.</li></ul> <p><b>(i) In the case of TK compressors pay attention to the correct assembly position of the pistons (suction fin grooves, Fig. 32)!</b></p>
290, 300	<ul style="list-style-type: none"><li>Install the oil scraper rings and the compression rings of the pistons, afterwards turn them by 30°.</li></ul> <p><b>(i) The butt joints may not lying upon each other (Fig. 32) Fit with the marking "TOP" facing upwards!</b></p>

Fig. 32

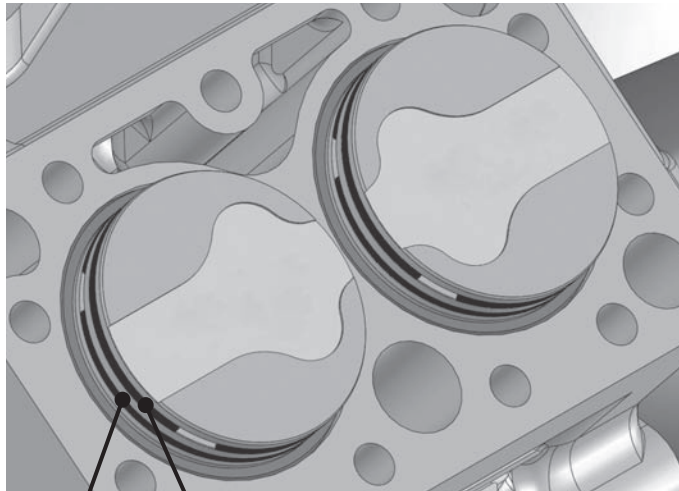

Oil scraper ring

Compression ring



Step

**5**

## Fitting the crankshaft

Parts list position: **2050**

Tools: -

Pos. in  
parts list

Working course

- Fit the crankshaft so that the drive journal engages into the gump gear.

Fig. 33

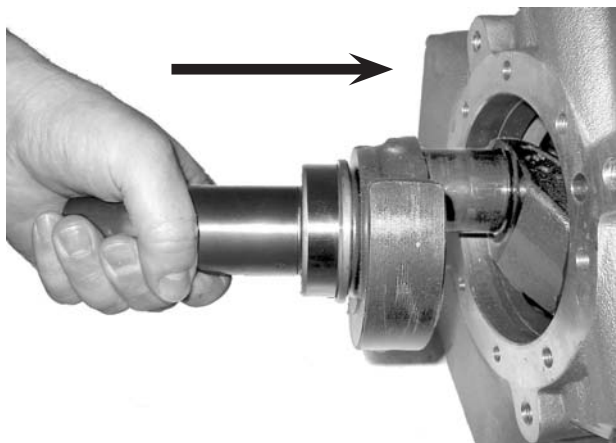

Step

6

## Installation of the front bearing flange

Partsl ist position: **2140**

Tools: **Allen key 6 mm**



**Observe the tightening torques (see table on page 55)!**

Pos. in  
parts list

Working course

745  
730, 740

- Apply oil to the O-ring and place it into the groove in the bearing flange.
- Install the front bearing flange with oiled gasket to the body so that the hole for the leak oil collection ring faces upwards.

750

- Tighten the screws.

Fig. 34

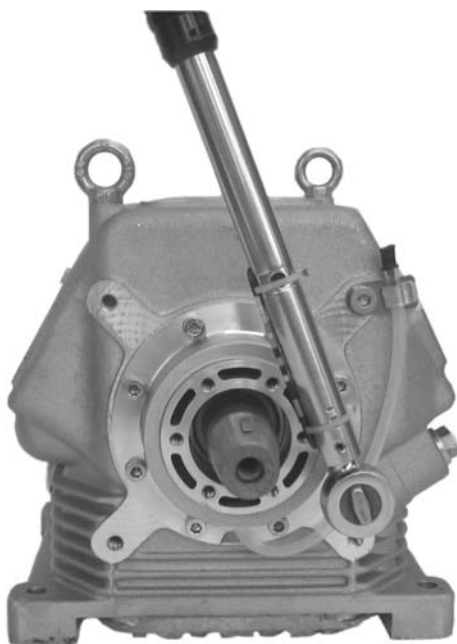

Step

7

## Assembly of the inserted connecting rods / pistons

Parts list position: 2040

Tools: Piston ring plier, spanner 10 mm



**Pay attention to the correct pairing of connecting rods and connecting rod caps!  
Replace connecting rod cap screws or in the case of reusing put on a sticker!  
Observe the tightening torques (see table on page 55)!**

Pos. in  
parts list

Working course

290, 300

- Compress the oil scraper ring and compression ring with the piston ring plier and insert the piston into the cylinder liner.

2100

- Place the marked connecting rod caps onto the related connecting rods.
- Screw on the connecting rod caps and tighten.
- Turn the crankshaft by hand. In case the crankshaft does not rotate freely check the seating of the connecting rods; if necessary, disassemble the connecting rods and carry out this step once more.

Fig. 35a



Fig. 35b





Step

## Install of the oil pump

8

Parts list position: **2020**

Tools: **Spanner 13 mm**



**Observe the tightening torques (see table on page 55)!**

Pos. in  
parts list

Working course

460, 470

• Install the oil pump with oil gasket into the body with the inscription „TOP“ facing upwards.

**(i) Pay attention to the position of the holes in the gasket (Fig. 36a)!**

40

• Tighten the oil pump screws crosswise

Pay attention to the tightening sequence of the oil pump screws (Fig. 36b)!

Fig. 36a



Fig. 36b

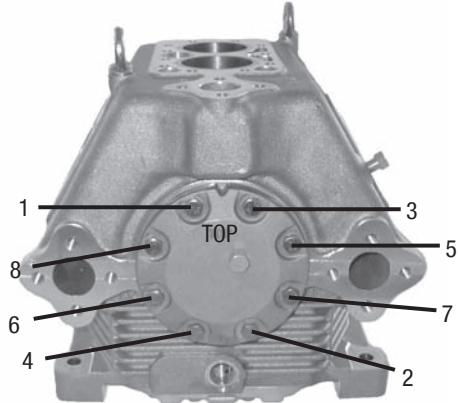

Tightening sequence  
for oil pump screws



### Adjust end play!

The end play of the crankshaft should be minimum 0,1 mm. When parts of the driving unit of the compressor have been repaired or replaced, an accurate measurement of the end play is necessary. The measurement has to be at the disassembly friction ring cover. Will the play of the crankshaft be **less than 0,15 mm**, the bearing flange has to be disassembled and a second seal has to be inserted (Fig. 36d).

Fig. 36c

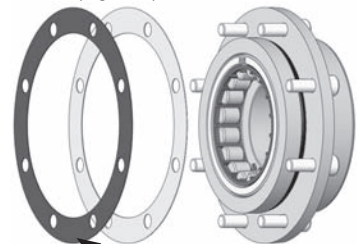
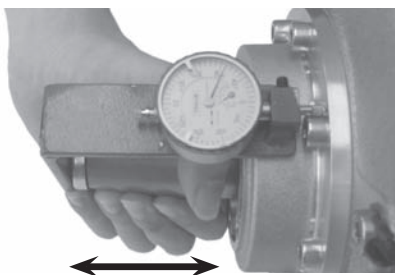

Fig. 36d second seal

Step

9

**Fitting the shaft seal**

Parts list position: 2010

Tools: Allen key 6 mm

**Watch out! Avoid damages! Pay attention to the markings! Apply a little oil to the parts! Observe tightening torques (see table on page 55)!**Pos. in  
parts list

Working course

- | Pos. in parts list | Working course   |
|--------------------|--|
|                    | <ul style="list-style-type: none"> <li>● Push the compression spring onto the crankshaft. Rotate the spring until the driving catch is engaged in the crankshaft.</li> <li>● Push the guide ring with O-ring and sliding ring onto the crankshaft. Rotate all parts until the spring is engaged in the guide ring. Avoid scratches on the sliding ring!</li> </ul> |
| 880                | <ul style="list-style-type: none"> <li>● Install the shaft seal cover with the gasket. The inscription „TOP“ must be at the top.</li> </ul>  |
| 750                | <ul style="list-style-type: none"> <li>● Press the shaft seal cover onto the bearing flange and tighten the screws.</li> <li>● Turn the crankshaft by hand (it now moves with a little more difficulty).</li> </ul>  |
| 2110               | <ul style="list-style-type: none"> <li>● Install the leak oil collection device (only up to design key 013, Fig. 37) and see also under service-kits: Leak oil collection device.</li> </ul>   |

Fig. 37a



Fig. 37b



Fig. 37c

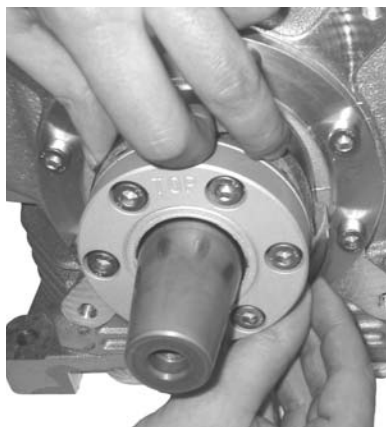

Fig. 37d

Step

10

## Installation of the baseplate

Parts list position: 20

Tools: Spanner 13 mm



Observe the tightening torques (see table on page 55)!

Pos. in  
parts list

Working course

20, 30, 40

- Install the baseplate with gasket and tighten the M8x30 screws.  
Pay attention to the tightening sequence of the baseplate screws!

Fig. 38a

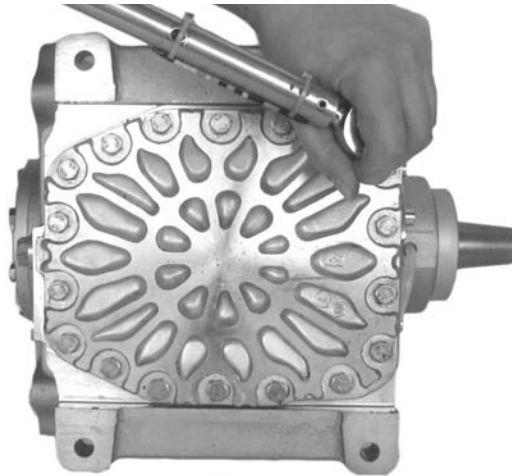
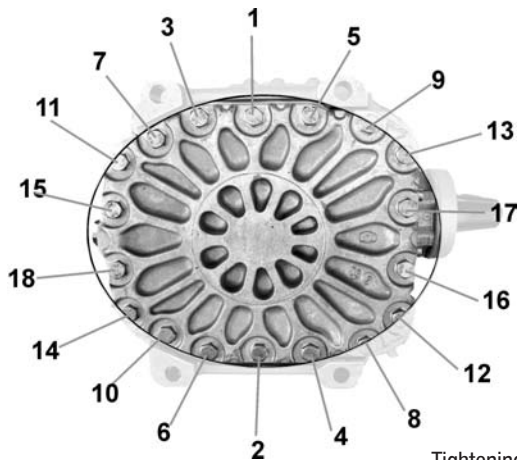

Fig. 38b



Tightening sequence of base-plate screws

Step

11

## Installation of the oil filter

Parts list position: 2130

Tools: Allen key 10 mm, Spanner SW 19



**Observe the tightening torques (see table on page 55)!**

Pos. in  
parts list

Working course

- |     |   |
|-----|---|
| 490 | ● With the allen key, screw on the filter into the hole in the body and tighten it. |
| 500 | ● Install gasket.   |
| 510 | ● Screw on the M22x1.5 mm plug and tighten it.                                      |

Fig. 39a

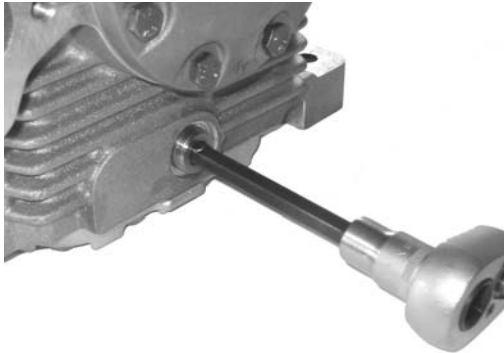
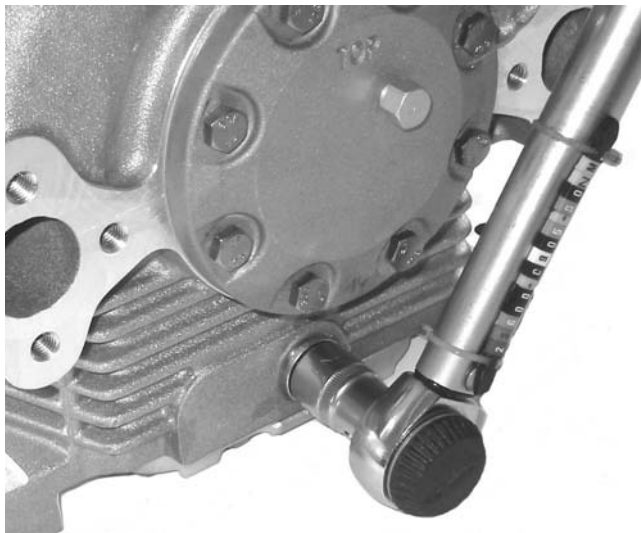

Fig. 39b



Step

12

**Installation of the cylinder covers and valve plates**

Parts list position: 170, 2000 (N / TK versions), 1940, 2900 (K versions)

Tools: Spanner 17 mm

**Install only the cylinder covers and valve plates which belong together, avoid mix-ups! Observe the tightening torques (see table on page 55)!**

Pos. in N / TK	parts list K	Working course
60, 50 70, 170	1920, 1910 1930, 1940	See page 21-22 <ul style="list-style-type: none"> <li>Mount the valve plate with the lower valve plate gasket onto the body.</li> <li>Mount the cylinder cover with the upper valve plate gasket (see Fig. 40a)</li> </ul>
180	1950	<ul style="list-style-type: none"> <li><b>Mount the K type plate with the marking „TOP“ facing upwards!</b></li> <li>Tighten the screw cross-wise in at least two steps. Pay attention to the tightening sequence of the cylinder cover screws! (see Fig. 40b)</li> </ul>

Fig. 40a

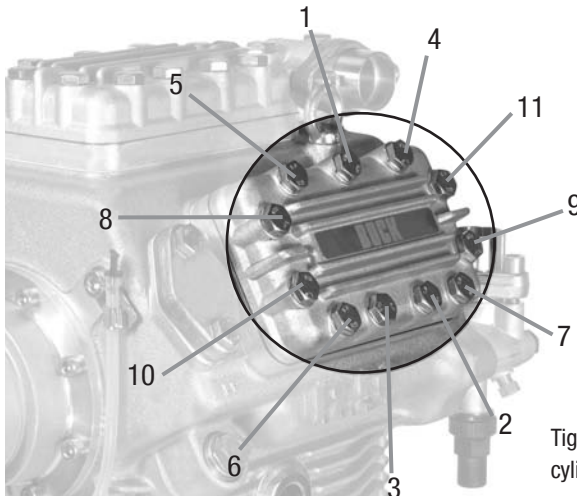

Fig. 40b

Tightening sequence for  
cylinder cover screws

Step

13

## Installation of the shut-off valves and blind flanges

Parts list position: 2060, 2070, 232

Tools: Spanner 17 mm



**Apply oil gaskets; observe tightening torques (see table on page 55)!  
Use screws of correct length for the installation of the intermediate flanges!**

Pos. in  
parts list

Working course

230, 210  
220, 210

- Put in the suction filter with the gasket.
- Install the shut-off valves (on the discharge and suction side) with gaskets and screws.



**If there is an intermediate flange: Use screws of correct length.**

232, 231

- Install the blind flange with seals and screws.
- Tighten all screws; observe tightening torques!

Fig. 41a

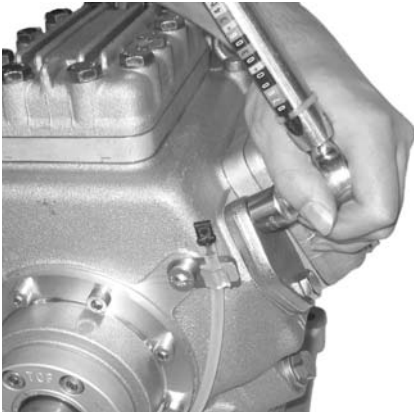

Fig. 41b



Fig. 41c

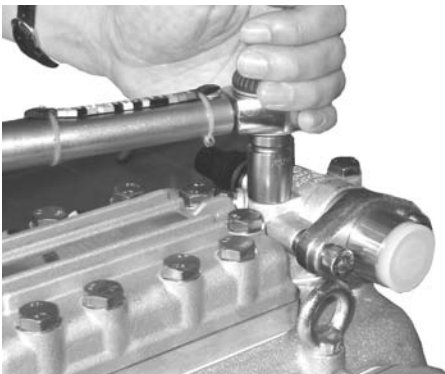

Fig. 41d



# Checking the compressor

Working course

## 1. Evacuation / leak check of compressor

- Connect the discharge and suction sides of the compressor to a vacuum pump.
- Evacuate the compressor from both sides; vacuum < 1,5 mbar. Check increase in pressure.
- In case there is an increase in pressure, check the compressor for leaks and evacuate again.
- Fill in the stipulated amount of oil (2,6 liters).

## 2. Carrying out the function test

- Install the compressor in the system.
- Carry out a leak test with refrigerant.
- Make a test run. During this, check the oil level, the leak-tightness of the compressor, the running noise, pressure, temperatures and the functioning of additional devices such as the capacity regulation.

**Remark:** If the compressor is going to remain in the warehouse, charge it with nitrogen (at about 3 bar pressure) for protection.



**Attention! Take the reminders for commissioning in the operating manual for FK50 into account!**

## Tightening torques for screwed fastenings

**General fastenings** with fibrous or metallic flat gasket

Screw size	Tightening torque
M8	34 Nm
M10	60 Nm

**Reminder:** Cylinder cover / valve plate: Tighten the screws cross-wise in at least two steps (50 / 100 % of the tightening torque).

### Special fastenings

Designation	Thread size	Tightening torque
Shaft seal cover	M8	34 Nm
Connecting rod screw	M6	15 Nm
Oil filling plug Oil drain plug	M22 x 1,5 <sup>1)</sup>	60 Nm
Sight glass	1 1/8"-18 UNEF	25 Nm
Flanged connection Soldering gland-shut-off valves	M10	60 Nm
Plugs	1/8" NPTF	25 Nm
Electromagnetic clutch	M12	85 Nm
Safety valve	M24	100 Nm

<sup>1)</sup> With aluminium gasket

## Spare parts list

Pos.	Designation	Version	Piece	FK(X)50 / ...					
				460	555	660	775	830	980
20	Baseplate	N, K, TK	1	03876	03876	03876	03876	03867	03867
30	Baseplate gasket	N, K, TK	1	06721	06721	06721	06721	03876	03876
40	M8x30 Hexagon head screw	N, K, TK	26	06244	06244	06244	06244	06721	06721
41	Disc B8,4	N, K, TK	26	05644	05644	05644	05644	05644	05644
50	Lower valve plate gasket Ø 55	N, TK	3	05695	05695	—	—	—	—
50	Lower valve plate gasket Ø 60	N, TK	3	—	—	05696	—	—	—
50	Lower valve plate gasket Ø 65	N, TK	3	—	—	—	05697	—	05697
60	Valve plate, complete Ø 50 / 55	N, TK	3	07117	07117	—	—	—	—
60	Valve plate, complete Ø 60 / 65	N, TK	3	—	—	07118	07118	07118	07118
70	Upper valve plate gasket	N, TK	3	06730	06730	06730	06730	06730	06730
80	Eye bolt M8	N,K, TK	2	06381	06381	06381	06381	06381	06381
100	Safety valve for 28bar operation	N,K, TK	3	07940	07940	07940	07940	07940	07940
110	Seal ring 27,8x24,2x2	N,K, TK	3	05791	05791	05791	05791	05791	05791
170	Cylinder cover	N, TK	3	03384	03384	03384	03384	03384	03384
180	M10x65 Hexagon head screw	N, TK	33	06034	06034	06034	06034	06034	06034
181	Disc B10,5	N,K, TK	33	05646	05646	05646	05646	05646	05646
210	Valve flange gasket	N, K, TK	3	05083	05083	—	—	—	—
210	Valve flange gasket	N, K, TK	5	—	—	05083	05083	05083	05083
220	M10x65 Hexagon head screw	N, K, TK	4	06034	06034	—	—	—	—
220	M10x65 Hexagon head screw	N, K, TK	6	—	—	06034	06034	—	—
221	Disc B10,5	N, K, TK	4	05646	05646	05646	05646	05646	05646
230	Filter, suction side	N, K, TK	1	03370	03370	—	—	—	—
230	Filter, suction side	N, K, TK	2	—	—	03370	03370	03370	03370
231	Valve flange gasket	N, K, TK	1	05083	05083	—	—	—	—
232	Blind flange 15 mm	N, K, TK	1	04269	04269	—	—	—	—
233	Screw M10x25	N, K, TK	2	05447	05447	—	—	—	—
270	Piston pin Ø 15x10x41	N, K, TK	6	07211	—	—	—	—	—
270	Piston pin Ø 15x10x46	N, K, TK	6	—	07212	—	—	07212	—
270	Piston pin Ø 15x10x50	N, K, TK	6	—	—	07857	07857	—	07857
280	Seeger circlip 15x1, DIN 472	N, K, TK	12	05551	05551	05551	05551	05551	05551
290	Oil control ring piston 50	N, K, TK	6	05389	—	—	—	—	—
290	Oil control ring piston 55	N, K, TK	6	—	05390	—	—	—	—
290	Oil control ring piston 60	N, K, TK	6	—	—	06562	—	50506	—
290	Oil control ring piston 65	N, K, TK	6	—	—	—	06572	—	50507
300	Compression ring piston 50	N, K, TK	6	05379	—	—	—	—	—
300	Compression ring piston 55	N, K, TK	6	—	05380	—	—	—	—
300	Compression ring piston 60	N, K, TK	6	—	—	06563	—	50508	—
300	Compression ring piston 65	N, K, TK	6	—	—	—	06564	—	50509
310	Cyl. roller bearing NJ210EX5TNG C3	N, K, TK	2	07755	07755	07755	07755	07755	07755
312	Clearance ring for bearing Ø 90	N, K, TK	1	05280	05280	05280	05280	05280	05280
320	Cap nut M22x1,5	N, K, TK	2	05784	05784	—	—	—	—
320	Cap nut M22x1,5	N, K, TK	3	—	—	05784	05784	05784	05784
321	Cap nut 7/16" UNF	N, K, TK	2	05789	05789	—	—	—	—
321	Cap nut 7/16" UNF	N, K, TK	3	—	—	05789	05789	05789	05789
322	Locking screw 1/8" NPTF	N, K, TK	2	05514	05514	—	—	—	—
322	Locking screw 1/8" NPTF	N, K, TK	3	—	—	05514	05514	05514	05514
330	Shut-off valve (AL)	N, K, TK	2	07130	07130	—	—	—	—
330	Shut-off valve (AL)	N, K, TK	3	—	—	07130	07130	07130	07130
331	Valve flange gasket	N, K, TK	1	05083	05083	05083	05083	05083	05083



Pos.	Designation	Version	Piece	FK(X)50/...					
				460	555	660	775	830	980
332	Blind flange 15 mm	N, K, TK	1	04269	04269	04269	04269	04269	04269
333	M10x35 Hexagon head screw	N, K, TK	2	05447	05447	05447	05447	05447	05447
340	Gasket soldered connect. 42x34x1	N, K, TK	2	05067	05067	—	—	—	—
340	Gasket soldered connect. 42x34x1	N, K, TK	3	—	—	05067	05067	05067	05067
350	Brazed hexagon nipple Ø 28	N, K, TK	1	04367	04367	—	—	—	—
350	Brazed hexagon nipple Ø 35	N, K, TK	1	—	—	05313	05313	05313	05313
355	Flange oval 16 mm	N, K, TK	2	04329	04329	—	—	—	—
355	Flange oval 16 mm	N, K, TK	3	—	—	04329	04329	04329	04329
355	Flange oval 16 mm	N, K, TK	3	—	—	04329	04329	04329	04329
360	Brazed hexagon nipple Ø 35	N, K, TK	1	05313	05313	—	—	—	—
360	Brazed hexagon nipple Ø 35	N, K, TK	2	—	—	05313	05313	05313	05313
370	Cylinder screw M10x35	N, K, TK	2	05489	05489	—	—	—	—
370	Hexagonal head screw M10x35	N, K, TK	4	—	—	05489	05489	05489	05489
380	Cylinder screw M10x35	N, K, TK	2	—	—	05489	05489	05489	05489
380	Hexagonal head screw M10x35	N, K, TK	2	05447	05447	—	—	—	—
460	Oil pump, complete	N, K, TK	1	07990	07990	07990	07990	07990	07990
470	Gasket f. oilp. + rear bear. flange	N, K, TK	1	05094	05094	05094	05094	05094	05094
490	Oil filter	N, K, TK	1	06723	06723	06723	06723	06723	06723
500	Seal ring 27x22x2	N, K, TK	2	05342	05342	05342	05342	05342	05342
510	Locking screw M22x1,5	N, K, TK	2	06400	06400	06400	06400	06400	06400
520	Locking screw 1/8" NPTF	N, K, TK	2	05514	05514	05514	05514	05514	05514
570	Sight glass - insert Ø18 up to design key 012	N, K, TK	2	06026	06026	06026	06026	06026	06026
570	Sight glass - insert Ø22 as of design key 013	N, K, TK	2	05361	05361	05361	05361	05361	05361
590	O-Ring Ø 23, 52x1, 78 up to design key 012	N, K, TK	2	05142	05142	05142	05142	05142	05142
590	O-Ring Ø 28, 30x1, 78 as of design key 013	N, K, TK	2	06352	06352	06352	06352	06352	06352
726	Cylinder screw M10x10	N, K, TK	1	06169	06169	06169	06169	06169	06169
727	Cable / hose holder	N, K, TK	1	03860	03860	03860	03860	03860	03860
728	Cable / hose clamp	N, K, TK	1	03861	03861	03861	03861	03861	03861
729	Haft plug Ø5 (PHT, BLACK.)	N, K, TK	1	50184	06726	06726	06726	06726	06726
730	Front bearing flange	N, K, TK	1	06726	06726	06726	06726	06726	06726
740	Front bearing flange gasket	N, K, TK	1	06165	06165	06165	06165	06165	06165
745	O-Ring Ø 101, 19x3, 53	N, K, TK	1	05169	05169	05169	05169	05169	05169
750	Cylinder screw M8x25	N, K, TK	14	06067	06067	06067	06067	06067	06067
790	Woodruff key A5x9 DIN 6888	N, K, TK	1	05673	05673	05673	05673	05673	05673
800	Disc Ø 50x12, 5x8	N, K, TK	1	04425	04425	04425	04425	04425	04425
810	Spring washer B12	N, K, TK	1	05666	05666	05666	05666	05666	05666
820	Hexagonal head screw M12x40	N, K, TK	1	05462	05462	05462	05462	05462	05462
880	Shaft seal cover gasket	N, K, TK	1	05063	05063	05063	05063	05063	05063
1910	Lower valve plate gasket Ø 50	K	3	06178	—	—	—	—	—
1910	Lower valve plate gasket Ø 55	K	3	—	06161	—	—	—	—
1910	Lower valve plate gasket Ø 60	K	3	—	—	06641	—	06641	—
1910	Lower valve plate gasket Ø 65	K	3	—	—	—	06642	—	06642
1920	Valve plate complete	K	3	07700	07700	07700	07700	07700	07700
1930	upper valve plate gasket	K	3	06162	06162	06162	06162	06162	06162
1940	Cylinder cover	K	3	03381	03381	03381	03381	03381	03381
1950	Hexagonal head screw M10x70	K	33	05457	05457	05457	05457	05457	05457

Pos.	Designation	Version	Piece	FK(X)50/...					
				460	555	660	775	830	980
3999	Mach. oil. SP46 / 1 Ltr. can	N, K, TK	1	02279	02279	02279	02279	02279	02279
3999	Mach. oil. SP46 / 5 Ltr. can	N, K, TK	1	02280	02280	02280	02280	02280	02280
3999	Mach. oil. SP46 / 20 Ltr. can	N, K, TK	1	02281	02281	02281	02281	02281	02281
	Only for R22 - compressors !								
3999	Mach. oil. SE55 / 1 Ltr. can	N, K, TK	1	02282	02282	02282	02282	02282	02282
3999	Mach. oil. SE55 / 5 Ltr. can	N, K, TK	1	02283	02283	02283	02283	02283	02283
3999	Mach. oil. SE55 / 10 Ltr. can	N, K, TK	1	02284	02284	02284	02284	02284	02284
	Only for X - compressors !								

## Repair set parts list

Pos.	Designation	Version	Piece	FK(X)50/...					
				460	555	660	775	830	980
2000	Set valve plate	N, TK	3	80243	80243	80244	80244	80244	80244
2010	Set shaft seal	N, K, TK	1	80023	80023	80023	80023	80023	80023
2020	Set oil pump	N, K, TK	1	80017	80017	80017	80017	80017	80017
2030	Set piston Ø 50 (optimized)	N, K	6	80102	—	—	—	—	—
2030	Set piston Ø 55 (optimized)	N, K	6	—	80103	—	—	—	—
2030	Set piston Ø 60 (optimized)	N, K	6	—	—	80104	—	80616	—
2030	Set piston Ø 65 (optimized)	N, K	6	—	—	—	80105	—	80617
2035	Set piston Ø 50 rilled, optimized	TK	6	80220	—	—	—	—	—
2035	Set piston Ø 55 rilled, optimized	TK	6	—	80107	—	—	—	—
2035	Set piston Ø 60 rilled, optimized	TK	6	—	—	80210	—	—	—
2035	Set piston Ø 65 rilled, optimized	TK	6	—	—	—	80225	—	—
2040	Set piston - con. rod 2 rings Ø50	N, K	6	80083	—	—	—	—	—
2040	Set piston - con. rod 2 rings Ø55	N, K	6	—	80084	—	—	—	—
2040	Set piston - con. rod 2 rings Ø60	N, K	6	—	—	80085	—	80018	—
2040	Set piston - con. rod 2 rings Ø65	N, K	6	—	—	—	80086	—	80619
2045	Set piston - con. rod Ø50 r. + opt.	TK	6	80425	—	—	—	—	—
2045	Set piston - con. rod Ø55 r. + opt.	TK	6	—	80246	—	—	—	—
2045	Set piston - con. rod Ø60 r. + opt.	TK	6	—	—	80247	—	—	—
2045	Set piston - con. rod Ø65 r. + opt.	TK	6	—	—	—	80248	—	—
2050	Set crankshaft 39 stroke, optimized	N, K, TK	1	80087	80087	80087	80087	—	—
2050	Set crankshaft 49 stroke, optimized	N, K, TK	1	—	—	—	—	80614	80614
2060	Set shut-off valve NW25(AL)	N, K, TK	1	80100	80100	—	—	—	—
2060	Set shut-off valve NW32(AL)	N, K, TK	1	—	—	80101	80101	80101	80101
2070	Set shut-off valve NW32(AL)	N, K, TK	1	80101	80101	—	—	—	—
2070	Set shut-off valve NW32(AL)	N, K, TK	2	—	—	80101	80101	80101	80101
2080	Set sight glass Ø18 up to design key 012	N, K, TK	2	08698	08698	08698	08698	08698	08698
2080	Set sight glass Ø22 as of design key 013	N, K, TK	2	08552	08552	08552	08552	08552	08552
2090	Set gaskets (not shown)	N, TK	1	80231	80231	80231	80231	80231	80231
2090	Set gaskets (not shown)	K	1	80089	80089	80089	80089	80089	80089
2100	Set connecting rod	N, K, TK	6	80090	80090	80090	80090	80090	80090
2110	Set coll. ring w. felt insert up to design key 013	N, K, TK	1	80129	80129	80129	80129	80129	80129

Pos.	Designation	Version	Piece	FK(X)50/...					
				460	555	660	775	830	980
2130	Set oil filter	N, K, TK	1	80076	80076	80076	80076	80076	80076
2140	Set front bearing flange	N, K, TK	1	80081	02280	02280	02280	02280	02280
2900	Set valve plate	K	3	80010	80010	80010	80010	80010	80010

## Parts list, optional accessories

Pos.	Designation	Version	Piece	FK(X)50/...					
				460	555	660	775	830	980
3200	Set cap. reg. LR 87 24V with cylinder cover	N, TK	1	08704	08704	08704	08704	08704	08704
3220	Cylinder cover for LR	N, TK	1	03383	03383	03383	03383	03383	03383
3240	Upper valve plate gasket	N, TK	1	06730	06730	06730	06730	06730	06730
3250	Hexagonal head screw M10x70	N, TK	11	05457	05457	05457	05457	05457	05457
3300	Set cap. regulation LR 87, 24 V	N, K, TK	1	08418	08418	08418	08418	08418	08418
3310	Valve body LR 87	N, K, TK	1	07541	07541	07541	07541	07541	07541
3311	O-Ring Ø 48, 0x2, 5 green	N, K, TK	1	05987	05987	05987	05987	05987	05987
3312	Disc Ø 30x16x2, 0	N, K, TK	1	05143	05143	05143	05143	05143	05143
3313	Milled nut M15x1 with O-Ring	N, K, TK	1	05885	05885	05885	05885	05885	05885
3320	Solenoid coil, 24 V CC	N, K, TK	1	07526	07526	07526	07526	07526	07526
3800	Set cap. reg. LR 87 24V with cylinder cover	K	1	80022	80022	80022	80022	80022	80022
3820	Cylinder cover for LR	K	1	03323	03323	03323	03323	03323	03323
3840	Upper valve plate gasket	K	1	06162	06162	06162	06162	06162	06162
3850	Hexagonal head screw M10x85	K	11	06338	06338	06338	06338	06338	06338

[www.bock.de](http://www.bock.de)

Bock Kältemaschinen GmbH  
Benzstraße 7  
D-72636 Frickenhausen  
Telefon +49 7022 9454-0  
Telefax +49 7022 9454-137  
mail@bock.de

QUALITY SYSTEM



certified by DQS according to  
DIN EN ISO 9001 Reg. No. 2177



Art-Nr. 96022-07.09-DGbTrRc  
Subject to change without notice